

## ECE 474 OPTICAL COMMUNICATION SYSTEMS+LAB

### COURSE CONTENTS

1. Introduction to Optical Fibers
2. Propagation of Light in Optical Fibers
3. Mode Structure in Optical Fibers
4. Optical Fiber Communications Link Design
5. Attenuation in Optical Fibers, Power Budget Analysis
6. Dispersion in Optical Fiber Communications
7. Optical Sources and Detectors used in Optical Fiber Systems
8. Optical Fiber Transmitter
9. Optical Receiver Systems
10. Introduction to Free Space Optics (FSO) Systems
11. Propagation of Light in FSO
12. FSO Link Design
13. Optical Wireless Communication in Underwater Medium
14. All Optical Networking

### **TEXT BOOK:**

1. NAME : Textbook on Optical Fiber Communication and its Applications  
AUTHOR : S. C. Gupta  
PUBLISHER : PHI Learning Private Limited  
ISBN : 978-81-203-4580-5  
EDITION : 2012

### **GRADING:**

1	MID TERM EXAM (IN CLASS)	:	30 %
1	FINAL EXAM (IN CLASS)	:	40 %
	LAB	:	20 %
	LAB ATTENDANCE:	:	5 %
	ATTENDANCE IN CLASS	:	5 %
	:		
		TOTAL :	100 %

## 1. Introduction to Optical Fibers

Optical communication is one of the oldest methods of communicating.

The principle of optical communication is to use the light energy to send a message from one point to another. By light energy we mean the infra-red, visible and ultra-violet regions of the electromagnetic spectrum.

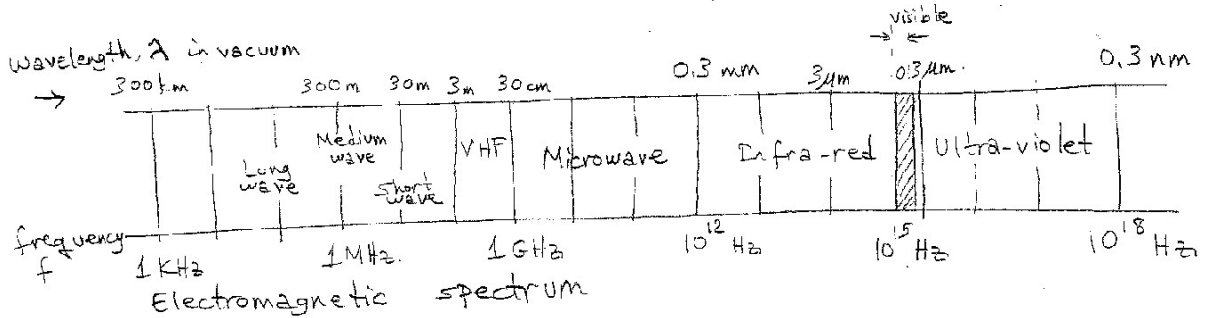

$$c = \lambda f = 3 \times 10^8 \text{ m/sec}$$

The realization of an optical communication system involves a light source, modulator, (transmitting lens), transmission medium, a light detector, receiver, (repeater), transmitter and receiver electronics, processing.

The simplest system is a man turning a flashlamp on and off and another person watching him.

On-off switch

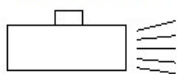

Flash lamp

transmission medium

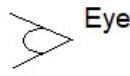

Eye

Here the light source is the flash lamp, turning the switch on and off corresponds to modulation, the transmission medium is the atmosphere, the eye is the detector, human brain is the processor. The data rate we provide depends on how fast we can turn the flashlamp on and off.

The factors to be considered in such a simple system are:

- The overall cost of the system,
- Frequency of the light source (carrier frequency),
- Frequency should match the operating frequency of the detector,
- Bandwidth of the light source (causes dispersion, i.e., broadening of the received pulse),
- Modulation rate (bit rate with unit bit/second). Limited by the switching electronics. Modulation rate determines the rate of information, i.e., what amount of data can be sent in one second,
- Medium losses (attenuation). Free space loss, absorption and scattering,
- Dispersion in the medium, i.e., widening of the received pulse which results in the reduction of the bit rate that can be used,
- Detector operating frequency that should match the source carrier frequency,
- Detector response time which should be fast enough to accommodate the modulation rate

If the distance is long then a person will be in the middle to convey the message (repeater).

Types of optical communication systems:

- a) Free space systems. Space-to-space satellite links. (Unguided).
- b) Atmospheric systems. Horizontal terrestrial links, earth to satellite links, satellite to earth links. (FSO, Free Space Optics) (Unguided)
- c) Oceanic (underwater) systems. Guided systems with optical fiber and unguided wireless systems.
- d) Optical fiber systems under and above the ground. Guided.

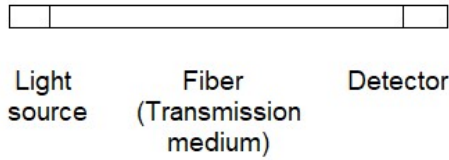

Advantages of optical fiber systems over the coaxial twisted wire systems:

- High repeater spacing possible (100 km or more),
- Potential of extremely high data bit rate. Terabit per second =  $10^{12}$  bps or more. Around million million TV channels or billions of telephone channels or Tbps internet traffic,
- Low weight,
- Low cost,
- No electromagnetic interference (EMI),
- High security. Tapping of the signal by unauthorized persons is not possible.

Most optical fiber systems utilize PCM (Pulse Code Modulation).

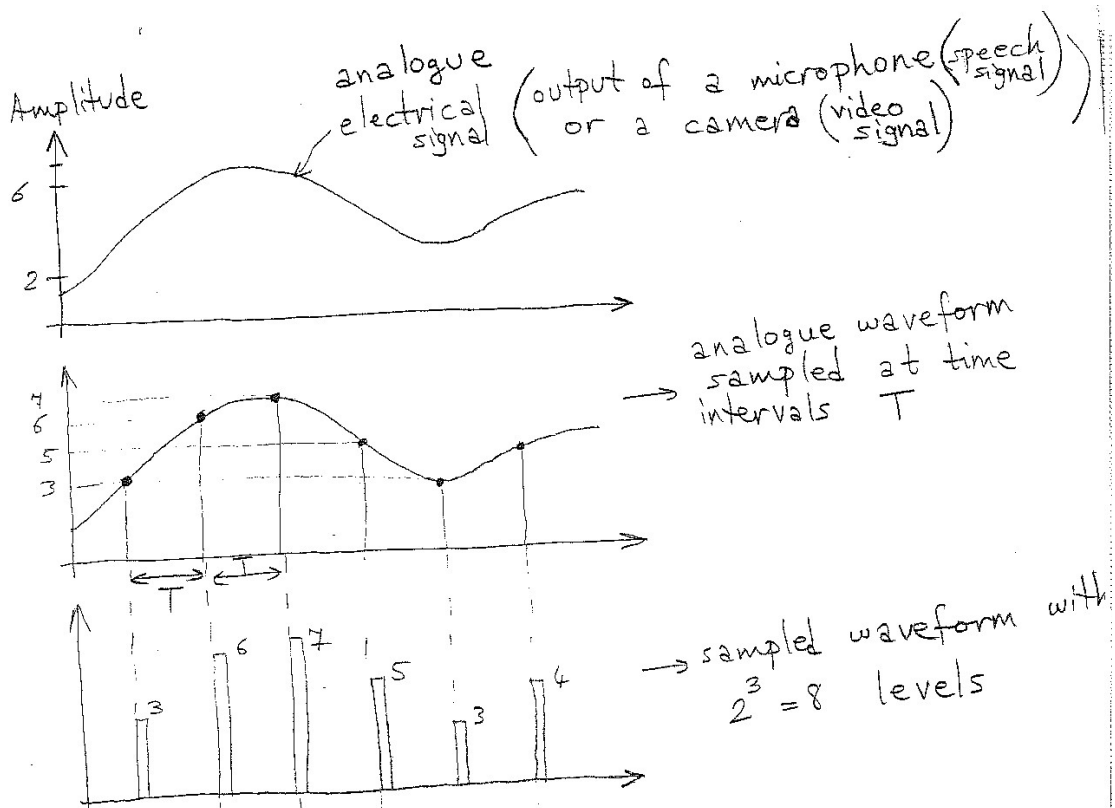

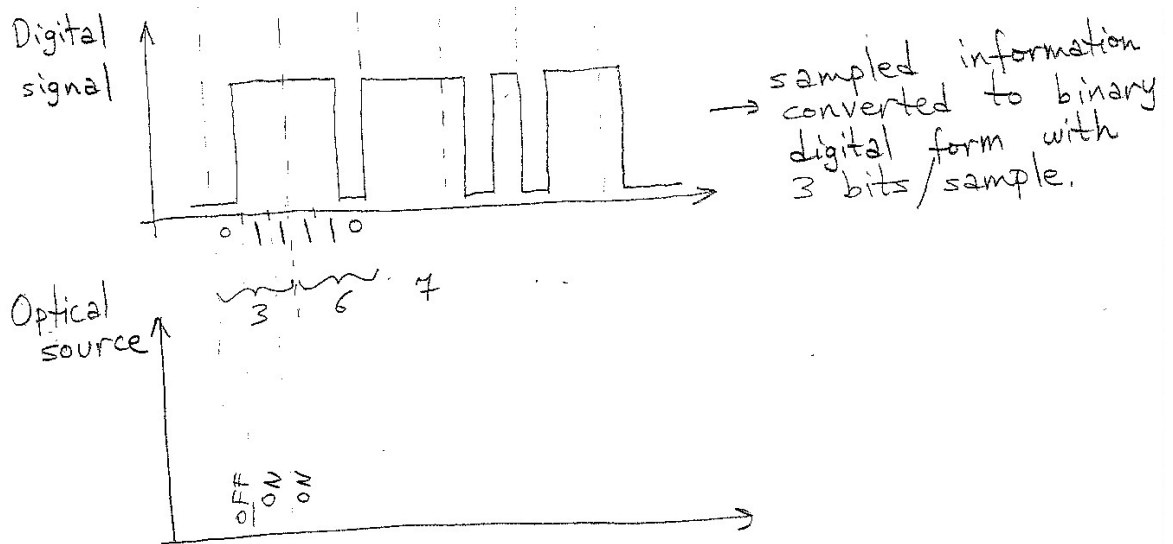

### Basic optical communication system architecture

#### Block diagram:

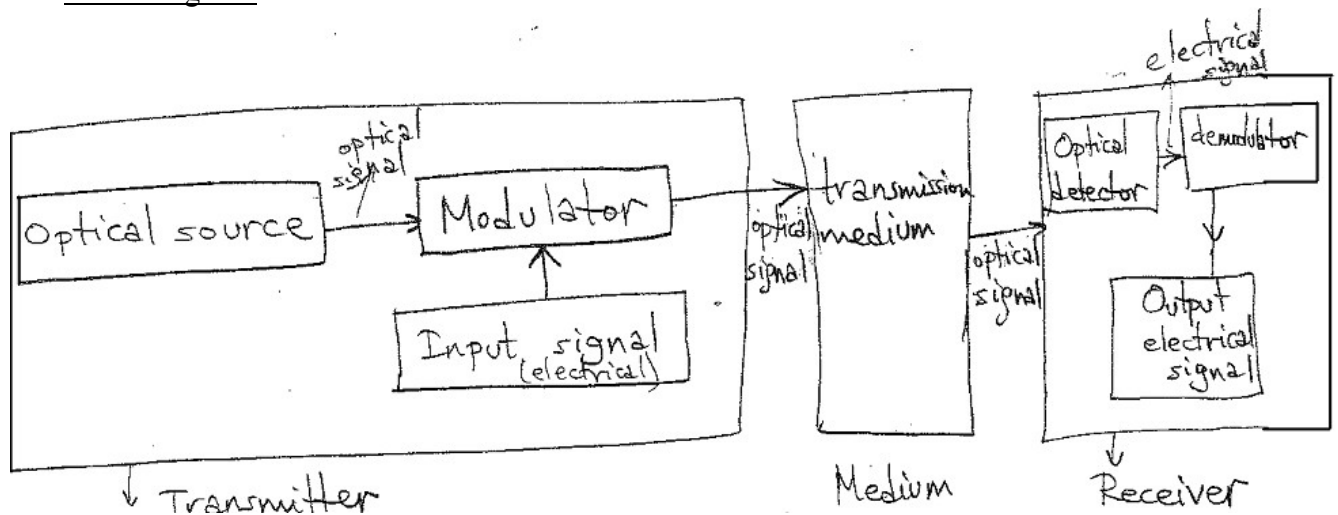

#### Main components of optical fiber systems:

1. The optical source: LED (semiconductor), laser diode (semiconductor),
2. A means of modulating the optical output from the source with the signal to be transmitted (internal modulation),
3. The transmission medium: Step index fibers (single mode, multimode), graded index fibers (multimode)
4. The photodetector which converts the received the received optical power back into an electrical signal. Pin (semiconductor), avalanche (semiconductor),
5. Electronic amplification and signal processing required to recover the signal and present it in a form suitable to use.
6. Connectors (source to fiber, fiber to fiber, fiber to photo detector) and splicing (fiber to fiber).

## 2. Propagation of Light in Optical Fibers

### Total internal reflection

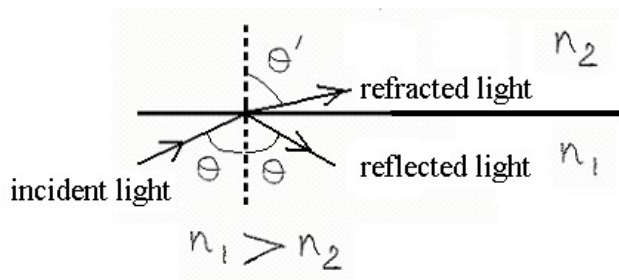

At the critical angle

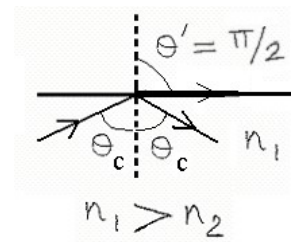

From Snell's Law,  $n_1 \sin \theta = n_2 \sin \theta'$

$\theta_c \triangleq \theta$  at which  $\theta' \triangleq \pi/2$  is the critical angle

Thus when  $\theta' \triangleq \pi/2$ ,  $n_1 \sin \theta_c = n_2 \sin(\pi/2) = n_2 \Rightarrow \theta_c = \arcsin(n_2/n_1)$ .

For  $\theta > \theta_c$ , total internal reflection occurs with no losses at the boundary and the light ray is totally reflected at the interface.

i.e., when  $\theta$  is increased, there appears an angle  $\theta = \theta_c$  (called the critical angle) where the refracted ray becomes parallel to the interface. If  $\theta$  is further increased (i.e., for  $\theta > \theta_c$ ) all the energy contained within the incident light ray is reflected back into the same medium (i.e., the core) so no energy is refracted into the second medium. Thus, no energy is lost. This phenomenon is called total internal reflection.

Considering a cylindrical glass fiber where  $n_1 > n_2$ :

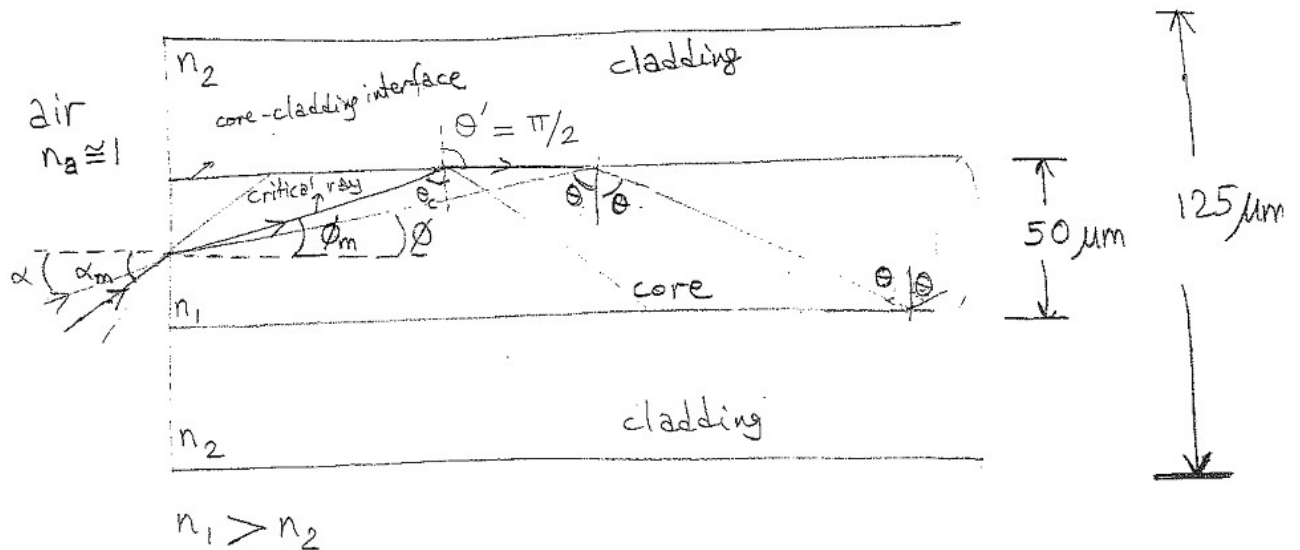

The ray enters the end face of the fiber from the outside (refractive index of air =  $n_a=1$ ).

For  $\theta > \theta_c$ , total internal reflections will occur and the ray will propagate along the fiber (in the core) without losing energy.

Writing Snell's Law at the air to fiber boundary

$$n_a \sin \alpha = n_1 \sin \phi = n_1 \sin \left( \frac{\pi}{2} - \theta \right) = n_1 \cos \theta$$

For  $n_a = 1$ ,  $\sin \alpha = n_1 \cos \theta$ ,

For the critical ray,  $n_a \sin \alpha_m = \sin \alpha_m = n_1 \cos \theta_c$

Inside the core,  $n_1 \sin \theta_c = n_2 \sin(\pi/2) \Rightarrow n_1 \sin \theta_c = n_2 \Rightarrow \sin \theta_c = \frac{n_2}{n_1}$

$$\text{So } \cos \theta_c = \sqrt{1 - \left( \frac{n_2}{n_1} \right)^2} = \sqrt{\frac{n_1^2 - n_2^2}{n_1^2}} = \frac{(n_1^2 - n_2^2)^{0.5}}{n_1}$$

Thus,  $\sin \alpha_m = (n_1^2 - n_2^2)^{0.5}$

Let  $\Delta n = n_1 - n_2$  and  $n = \frac{n_1 + n_2}{2}$

$$\sin \alpha_m = (2n\Delta n)^{0.5}$$

$\therefore$  The greater the value of  $\alpha_m$ , the greater is the proportion of the light incident onto the end face that can be collected by the fiber and be propagated by internal reflection.

$n_a \sin \alpha_m$  is defined as the numerical aperture (NA) which is a measure of light gathering power (acceptance cone) of the optical fiber. For  $n_a = 1$ ,  $NA = \sin \alpha_m = (n_1^2 - n_2^2)^{0.5}$ .

Conclusion is that in order for the fiber to guide the light, angle of incidence to fiber ( $\alpha$ ) should be less than  $\alpha_m$ .

If  $\alpha > \alpha_m$ , then refraction will occur at the core-cladding interface and the optical power is lost.

### 3. Mode Structure in Optical Fibers

#### Waveguide equations, wave and ray optics

Propagation of light within the fiber can be formulated using either the wave optics or the ray optics.

In wave optics, field theory is used to derive a wave equation in terms of the longitudinal components of the fields in the guide. Then using the transformation equation (derived using Maxwell's equations) the transverse components of the fields are found in terms of the longitudinal components. Various solutions of the wave equation determine the propagation of the modes within the fiber.

In ray optics, propagation of the modes are presented by rays following different paths.

### Basic waveguide equations; Wave optics

Consider the waveguide structure

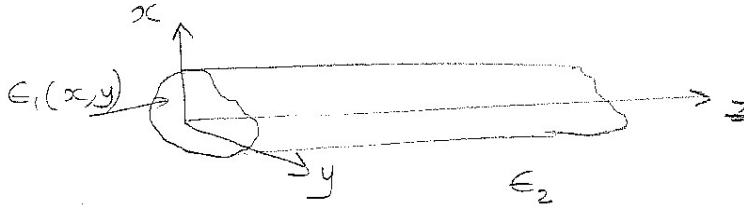

- Assume that the propagation is in z-direction with a longitudinal propagation constant  $\beta$  (i.e.,  $\beta$  is the longitudinal component of the propagation vector  $\bar{k}$ ).
- Assume that the permittivity  $\varepsilon(x, y)$  does not depend on  $z$  but can vary with  $x$  and  $y$ . However, it is assumed to vary small amounts over the region of the wavelength so  $\varepsilon$  is taken as constant.

The fields in a waveguide can be written as

$$\bar{E} = E_x \hat{a}_x + E_y \hat{a}_y + E_z \hat{a}_z$$

$$\bar{H} = H_x \hat{a}_x + H_y \hat{a}_y + H_z \hat{a}_z \quad (1)$$

where for  $e^{j\omega t}$  time dependence  $E_x = E_{x0}(x, y)e^{-j\beta z}e^{j\omega t}$

$$E_y = E_{y0}(x, y)e^{-j\beta z}e^{j\omega t} \quad (2)$$

$$E_z = E_{z0}(x, y)e^{-j\beta z}e^{j\omega t}$$

Here  $\beta$  = propagation constant in z-direction is to be determined.

Using the Maxwell's equations

$$\nabla \times \bar{E} = -\frac{\partial \bar{B}}{\partial t} = -\mu \frac{\partial \bar{H}}{\partial t} \quad (3)$$

$$\nabla \times \bar{H} = \frac{\partial \bar{D}}{\partial t} = \varepsilon \frac{\partial \bar{E}}{\partial t}$$

$$\left( \frac{\partial E_z}{\partial y} - \frac{\partial E_y}{\partial z} \right) \hat{a}_x + \left( \frac{\partial E_x}{\partial z} - \frac{\partial E_z}{\partial x} \right) \hat{a}_y + \left( \frac{\partial E_y}{\partial x} - \frac{\partial E_x}{\partial y} \right) \hat{a}_z = -\mu \frac{\partial H_x}{\partial t} \hat{a}_x - \mu \frac{\partial H_y}{\partial t} \hat{a}_y - \mu \frac{\partial H_z}{\partial t} \hat{a}_z \quad (4)$$

$$\left( \frac{\partial H_z}{\partial y} - \frac{\partial H_y}{\partial z} \right) \hat{a}_x + \left( \frac{\partial H_x}{\partial z} - \frac{\partial H_z}{\partial x} \right) \hat{a}_y + \left( \frac{\partial H_y}{\partial x} - \frac{\partial H_x}{\partial y} \right) \hat{a}_z = \varepsilon \frac{\partial E_x}{\partial t} \hat{a}_x + \varepsilon \frac{\partial E_y}{\partial t} \hat{a}_y + \varepsilon \frac{\partial E_z}{\partial t} \hat{a}_z$$

From Eq. (2),  $\frac{\partial E_x}{\partial t} = j\omega E_x$  and  $\frac{\partial E_x}{\partial z} = -j\beta E_x$  (5)

Substituting Eq. (5) into Eq. (4) and writing in component form

$$\frac{\partial H_z}{\partial y} + j\beta H_y = j\omega\epsilon E_x \quad (6a)$$

$$-j\beta H_x - \frac{\partial H_z}{\partial x} = j\omega\epsilon E_y \quad (6b)$$

$$\frac{\partial H_y}{\partial x} - \frac{\partial H_x}{\partial y} = j\omega\epsilon E_z, \quad (6c)$$

$$\frac{\partial E_z}{\partial y} + j\beta E_y = -j\omega\mu H_x, \quad (7a)$$

$$-j\beta E_x - \frac{\partial E_z}{\partial x} = -j\omega\mu H_y, \quad (7b)$$

$$\frac{\partial E_y}{\partial x} - \frac{\partial E_x}{\partial y} = -j\omega\mu H_z \quad (7c)$$

To express  $E_x, E_y, H_x, H_y$  in terms of  $E_z, H_z$ , we use Eqs. (6a) and (7b) to obtain

$$j\omega\epsilon E_x = \frac{\partial H_z}{\partial y} + \frac{j\beta}{-j\omega\mu} \left( -j\beta E_x - \frac{\partial E_z}{\partial x} \right) \quad (8)$$

Multiplying Eq. (8) by  $-j\omega\mu$  and rearranging

$$E_x = -\frac{j}{\kappa^2} \left( \omega\mu \frac{\partial H_z}{\partial y} + \beta \frac{\partial E_z}{\partial x} \right) \quad (9)$$

where  $\kappa^2 = k^2 - \beta^2$  and  $k^2 = \omega^2\mu\epsilon$

Similarly from Eqs. (6b) and (7b) we obtain

$$E_y = -\frac{j}{\kappa^2} \left( \beta \frac{\partial E_z}{\partial y} - \omega\mu \frac{\partial H_z}{\partial x} \right) \quad (10)$$

From (7a) and (6b)

i.e., from  $\frac{\partial E_z}{\partial y} + j\beta E_y = -j\omega\mu H_x$  and  $-j\beta H_x - \frac{\partial H_z}{\partial x} = j\omega\epsilon E_y$ , we obtain

$$H_x = -\frac{j}{\kappa^2} \left( \beta \frac{\partial H_z}{\partial x} - \omega \epsilon \frac{\partial E_z}{\partial y} \right) \quad (11)$$

From (7b) and (6a)

i.e., from  $-j\beta E_x - \frac{\partial E_z}{\partial x} = -j\omega\mu H_y$  and  $\frac{\partial H_z}{\partial y} + j\beta H_y = j\omega\epsilon E_x$ , we obtain

$$H_y = -\frac{j}{\kappa^2} \left( \beta \frac{\partial H_z}{\partial y} + \omega \epsilon \frac{\partial E_z}{\partial x} \right) \quad (12)$$

Now let us solve for  $E_z$  and  $H_z$  so that from (9)-(12) we can get the transverse fields.

Subst. (11) and (12) into (6c) and mult. by  $\frac{j\kappa^2}{\omega\epsilon}$  we have

$$\nabla_T^2 E_z + \kappa^2 E_z = 0 \quad \text{--- (13)}$$

where  $\nabla_T^2 = \frac{\partial^2}{\partial x^2} + \frac{\partial^2}{\partial y^2} =$  transverse laplacian operator

Similarly

$$\nabla_T^2 H_z + \kappa^2 H_z = 0 \quad \text{--- (14)}$$

Modes	Longitudinal components	Transverse comp
TEM (transverse electromagnetic)	$E_z = 0$ $H_z = 0$	$E_T, H_T$
TE (transverse electric)	$E_z = 0$ $H_z \neq 0$	$E_T, H_T$
TM (transverse magnetic)	$H_z = 0$ $E_z \neq 0$	"
HE or EH (hybrid)	$E_z \neq 0$ $H_z \neq 0$	"

In cylindrical coordinates one can obtain by transforming

$$\frac{\partial^2 E_z}{\partial r^2} + \frac{1}{r} \frac{\partial E_z}{\partial r} + \frac{1}{r^2} \frac{\partial^2 E_z}{\partial \phi^2} + K^2 E_z = 0$$

or  $E_z$  replaced by  $H_z$

$$E_r = -\frac{j}{K^2} \left( \beta \frac{\partial E_z}{\partial r} + \omega \mu \frac{1}{r} \frac{\partial H_z}{\partial \phi} \right)$$

$$E_\phi = -\frac{j}{K^2} \left( \beta \frac{1}{r} \frac{\partial E_z}{\partial \phi} - \omega \mu \frac{\partial H_z}{\partial r} \right)$$

$$H_r = -\frac{j}{K^2} \left( \beta \frac{\partial H_z}{\partial r} - \omega \epsilon \frac{1}{r} \frac{\partial E_z}{\partial \phi} \right)$$

$$H_\phi = -\frac{j}{K^2} \left( \beta \frac{1}{r} \frac{\partial H_z}{\partial \phi} + \omega \epsilon \frac{\partial E_z}{\partial r} \right)$$

## Ray Optics and Ray Equations

Ray optics describes the propagation of light in the form of rays. Ray optics can be applied to all phenomena that are described by the wave equation and that satisfy the requirement that  $\lambda$  is short compared to the dimensions of the guide.

Starting with the Helmholtz equation

$$\nabla^2 \bar{E} + k^2 \bar{E} = 0$$

If  $\psi$  is any rectangular component of  $\bar{E}$

$$\nabla^2 \psi + k^2 \psi = 0 \quad \text{————— (1)}$$

where  $k = nk_0 = n \left( \frac{2\pi}{\lambda_0} \right)$

↑  
propagation constant in vacuum

A solution in the form

$$\psi = \psi_0(x, y, z) e^{-jk_0 S(x, y, z)} \quad \text{————— (2)}$$

will be looked for. Here  $\psi_0$  and  $S$  are real functions of position.  $S(x, y, z)$  being the phase function associated with the medium and is called an "eikonal".

Substituting ② into ① and performing some algebra, it can be shown that for  $\lambda_0 \rightarrow 0$

$$\nabla S = n$$

known as the eikonal equation which determines the function  $S$  that defines the surfaces of constant phase by the equation

$$S(x, y, z) = \text{constant.}$$

The light rays are defined as the locus of points that form the orthogonal trajectories to the constant phase fronts of a light wave. i.e. if constant phase surfaces are known, one can construct the light rays by drawing lines perpendicular to the phase fronts. However it is often desirable to find the ray trajectories directly without having to construct the phase fronts.

→ Without derivation we state the paraxial (rays are nearly parallel to the  $z$ -axis) ray equations in cylindrical coordinates  $(r, \phi, z)$  as:

$$\frac{d^2 r}{dz^2} - r \left( \frac{d\phi}{dz} \right)^2 = \frac{1}{n_0} \frac{\partial n}{\partial r}$$

$$\frac{d}{dz} \left( r^2 \frac{d\phi}{dz} \right) = \frac{1}{n_0} \frac{\partial n}{\partial \phi}$$

→ In ray optics

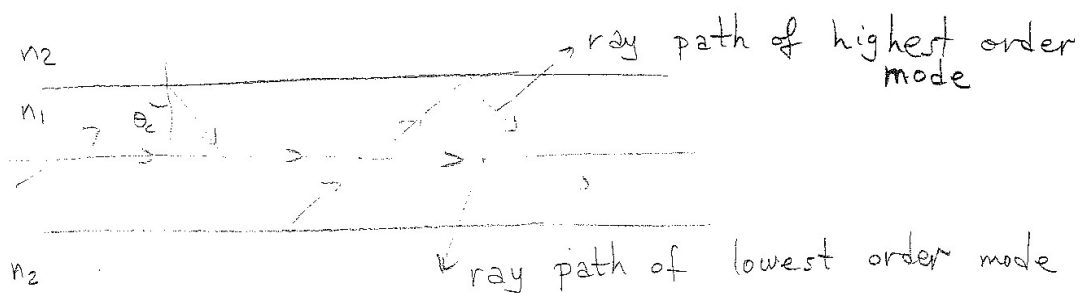

# The Step Index Fiber

The step index fiber has homogeneous core and homogeneous cladding.

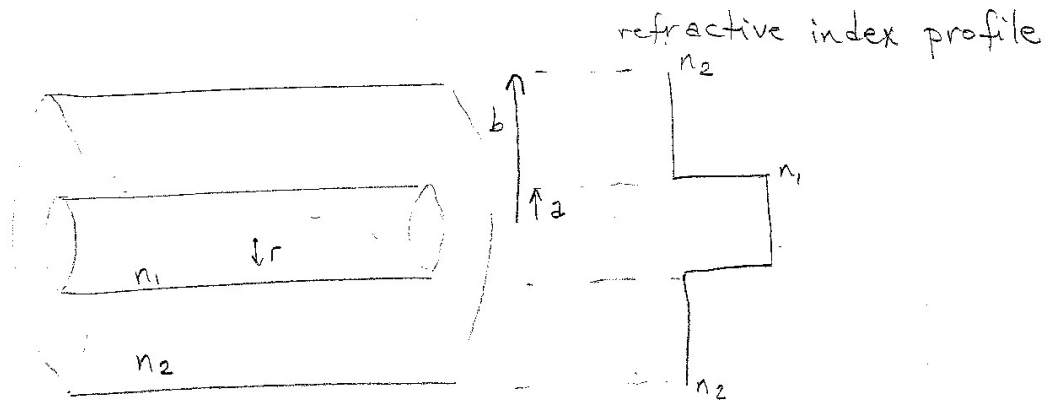

Assumption:  $b$  is large enough so that the cladding field decays exponentially and approaches zero at the cladding-air interface.

Equations satisfying  $E_z$  and  $H_z$  in cylindrical coord. are!

$$\frac{\partial^2 E_z}{\partial r^2} + \frac{1}{r} \frac{\partial E_z}{\partial r} + \frac{1}{r^2} \frac{\partial^2 E_z}{\partial \phi^2} + K^2 E_z = 0 \quad \text{--- (1)}$$

Longitudinal direction of propagation is in  $z$ -direction  
time dependence is  $j\omega t$  so that fields have dependence of the form  $e^{j(\omega t - \beta z)}$

Using separation of variables in (1)

$$E_z(\phi, r) = A \Phi(\phi) F(r) \quad \text{--- (2)}$$

Since fiber has circular symmetry, we choose

$$\Phi(\phi) = e^{j\nu\phi} \quad \text{--- (3)}$$

where  $\nu$  is (+ve or -ve) integer and

$$E_z = A F(r) e^{j\nu\phi} \quad \text{--- (4)}$$

Using (4) in (1) and mult. by  $1/A e^{j\nu\phi}$  we have

$$\frac{d^2 F(r)}{dr^2} + \frac{1}{r} \frac{dF(r)}{dr} + \left( K^2 - \frac{\nu^2}{r^2} \right) F(r) = 0 \quad \text{--- (5)}$$

This is a form of Bessel's equation. The solution should have the following properties:

- (i) The field in the core must be finite at  $r=0$
- (ii) Cladding field must have an exponentially decaying behavior at large distances from the center of the fiber.

The proper solution for (2) is

$$E_z = \begin{cases} A J_\nu(Kr) e^{j\nu\phi} & , r < a \\ C H_\nu^{(1)}(j\gamma r) e^{j\nu\phi} & , r > a \end{cases} \quad \text{--- (6)}$$

Similarly

$$H_z = \begin{cases} B J_\nu(Kr) e^{j\nu\phi} & , r < a \\ D H_\nu^{(1)}(j\gamma r) e^{j\nu\phi} & , r > a \end{cases} \quad \text{--- (7)}$$

where  $J_\nu$  is the Bessel function of order  $\nu$   
 $H_\nu^{(1)}$  " " modified Hankel function of the first kind of order  $\nu$   
 $A, B, C, D$  are unknown constants.

From Maxwell's equation  $E_r, E_\phi, H_r, H_\phi$  in the core are found as (ie transverse fields for  $r < a$ )

$$E_r = -\frac{j}{K^2} \left[ A \beta K J_\nu'(Kr) + B (j\nu)(\omega\mu) \frac{1}{r} J_\nu(Kr) \right] e^{j\nu\phi}$$

$\frac{\partial J_\nu(Kr)}{\partial (Kr)} = J_\nu'(Kr)$

$$E_\phi = -\frac{j}{K^2} \left[ j\beta \frac{\nu}{r} A J_\nu(Kr) - K\omega\mu B J_\nu'(Kr) \right] e^{j\nu\phi}$$

$$H_r = -\frac{j}{K^2} \left[ -j\omega\epsilon_1 \frac{\nu}{r} A J_\nu(Kr) + K\beta B J_\nu'(Kr) \right] e^{j\nu\phi} \quad \text{(8)}$$

$$H_\phi = -\frac{j}{K^2} \left[ K\omega\epsilon_1 A J_\nu'(Kr) + j\beta \frac{\nu}{r} B J_\nu(Kr) \right] e^{j\nu\phi}$$

where  $K^2 = k_1^2 - \beta^2 = \omega^2 \mu_0 \epsilon_1 - \beta^2$

Similarly the transverse field in the cladding are found as (i.e for  $r > a$ )

$$\begin{aligned} E_r &= -\frac{1}{\gamma^2} \left[ \beta \gamma C H_v^{(1)'}(j\gamma r) + \omega \mu_0 \frac{\nu}{r} D H_v^{(1)}(j\gamma r) \right] e^{j\nu\phi} \\ E_\phi &= -\frac{1}{\gamma^2} \left[ \beta \frac{\nu}{r} C H_v^{(1)}(j\gamma r) - \gamma \omega \mu_0 D H_v^{(1)'}(j\gamma r) \right] e^{j\nu\phi} \\ H_r &= -\frac{1}{\gamma^2} \left[ -\omega \epsilon_2 \frac{\nu}{r} C H_v^{(1)}(j\gamma r) + \gamma \beta D H_v^{(1)'}(j\gamma r) \right] e^{j\nu\phi} \\ H_\phi &= -\frac{1}{\gamma^2} \left[ \gamma \omega \epsilon_2 C H_v^{(1)'}(j\gamma r) + \beta \frac{\nu}{r} D H_v^{(1)}(j\gamma r) \right] e^{j\nu\phi} \end{aligned} \quad (9)$$

where 
$$\frac{\partial H_v^{(1)}(j\gamma r)}{\partial (j\gamma r)} = H_v^{(1)'}(j\gamma r)$$

$$\gamma^2 = \beta^2 - k_2^2 = \beta^2 - \omega^2 \mu_0 \epsilon_2$$

→ A, B, C, D and  $\beta$  is to be determined by applying the boundary conditions at the core-cladding interface ( $r = a$ )

→ Boundary conditions at  $r = a$  yield

$$\begin{aligned} \left. \begin{array}{l} \text{tangential} \\ E \text{ 's are} \\ \text{equal} \end{array} \right\} & \Rightarrow \begin{array}{l} E_{z_1} = E_{z_2} \\ E_\phi = E_\phi \end{array} \quad \begin{array}{l} \text{at } r = a \\ \text{" "} \end{array} \end{aligned} \quad (10)$$

$$\left. \begin{array}{l} \text{tangential} \\ H \text{ 's are} \\ \text{equal} \end{array} \right\} & \Rightarrow \begin{array}{l} H_{z_1} = H_{z_2} \\ H_\phi = H_\phi \end{array} \quad \begin{array}{l} \text{at } r = a \\ \text{" "} \end{array}$$

Here 1 are 2 refer to the core and the cladding respectively.

Using (6), (7), (8) and (9) in (10) one can obtain

$$[W] \begin{bmatrix} A \\ B \\ C \\ D \end{bmatrix} = [0]$$

where

$$W = \begin{bmatrix} J_V(Ka) & 0 & -H_V^{(1)}(j\gamma a) & 0 \\ \frac{V}{a} \frac{\beta}{K^2} J_V(Ka) & \frac{j\omega\mu_0}{K} J_V'(Ka) & \frac{V}{a} \frac{\beta}{\gamma^2} H_V^{(1)}(j\gamma a) & -\frac{j\omega\mu_0}{\gamma} H_V^{(1)'}(j\gamma a) \\ 0 & J_V(Ka) & 0 & -H_V^{(1)}(j\gamma a) \\ -\frac{j\omega\epsilon_1}{K_1} J_V'(Ka) & \frac{V}{a} \frac{\beta}{K^2} J_V(Ka) & \frac{\omega\epsilon_2}{\gamma} H_V^{(1)'}(j\gamma a) & \frac{V\beta}{2\gamma^2} H_V^{(1)}(j\gamma a) \end{bmatrix}$$

Nontrivial solution to (11) gives  
determinant of  $[W] = |W| = 0$

$|W| = 0$  gives the "eigenvalue" or the characteristic equation of the waveguide.

Characteristic equation can be found as

$$\left[ \frac{\epsilon_1}{\epsilon_2} \frac{a\gamma^2}{K} \frac{J_V'(Ka)}{J_V(Ka)} + j\gamma a \frac{H_V^{(1)'}(j\gamma a)}{H_V^{(1)}(j\gamma a)} \right] \left[ \frac{2\gamma^2 J_V'(Ka)}{K J_V(Ka)} + j\gamma a \frac{H_V^{(1)'}(j\gamma a)}{H_V^{(1)}(j\gamma a)} \right]$$

$$= \left[ V \left( \frac{\epsilon_1}{\epsilon_2} - 1 \right) \frac{\beta k_2}{K^2} \right]^2 \quad \text{--- (12)}$$

As in dielectric slab waveguide, (12) and

$R = \sqrt{(n_1^2 - n_2^2)} k_0 a$  circle will determine the modes of the step index fiber.

→ A, B, C, D constants can be found from (11)

→ Using (12) we find the characteristic equation for the

TE modes	when $V=0, E_z=0$	} meridional rays (crosses the axis)
TM "	" $V=0, H_z=0$	
HE	{ $H_z$ is the determining field	} skew rays
EH		

$V \neq 0$

## Mode cutoff conditions

At cut off  $\gamma = 0 = \sqrt{\beta_c^2 - k_{zc}^2}$

i.e. the field in the cladding ceases to be evanescent and detaches from the guide

$$\beta_c^2 = k_{zc}^2$$

$$k_{zc}^2 = \omega_c^2 \mu_0 \epsilon_2 \rightarrow \text{permittivity of the cladding.}$$

In the core - at cut off

$$K_c^2 = k_{1c}^2 - \beta_c^2 = \omega_c^2 \mu_0 \epsilon_1 - \beta_c^2 = \omega_c^2 \mu_0 \epsilon_1 - \omega_c^2 \mu_0 \epsilon_2$$

$\downarrow$   
permittivity of the core

$$\Rightarrow \omega_c = \frac{K_c}{\sqrt{\mu_0 (\epsilon_1 - \epsilon_2)}}$$

$\downarrow$   
cutoff frequency of a mode

- Cutoff frequency of a mode can be zero if  $K_c = 0$
- Only  $HE_{11}$  mode can exist in an optical fiber with  $\omega_c = 0$ , i.e. it is possible to design a single mode fiber
- Working on the characteristic equ. (12), letting  $\gamma \rightarrow 0$  and using the approximation for the modified Hankel function for small arguments, the cutoff conditions are obtained as.
- TE and TM modes  $\nu = 0$

Cutoff conditions for  $TE_{0\mu}$  and  $TM_{0\mu}$  modes are obtained from the  $\mu^{\text{th}}$  root of  $J_0(Ka) = 0$

→  $HE_{1\mu}$  modes

Cutoff condition  $K_c a = x_{\nu\mu}$  for  $\mu = 1, 2, 3$

where  $x_{\nu\mu}$  is the  $\mu^{\text{th}}$  root of  $J_\nu(x_{\nu\mu}) = 0$

$HE_{11}$  mode exists for all frequencies.

→  $EH_{\nu\mu}$  modes

Cutoff condition same as  $\rightarrow$  except

$$x_{\nu\mu} \neq 0$$

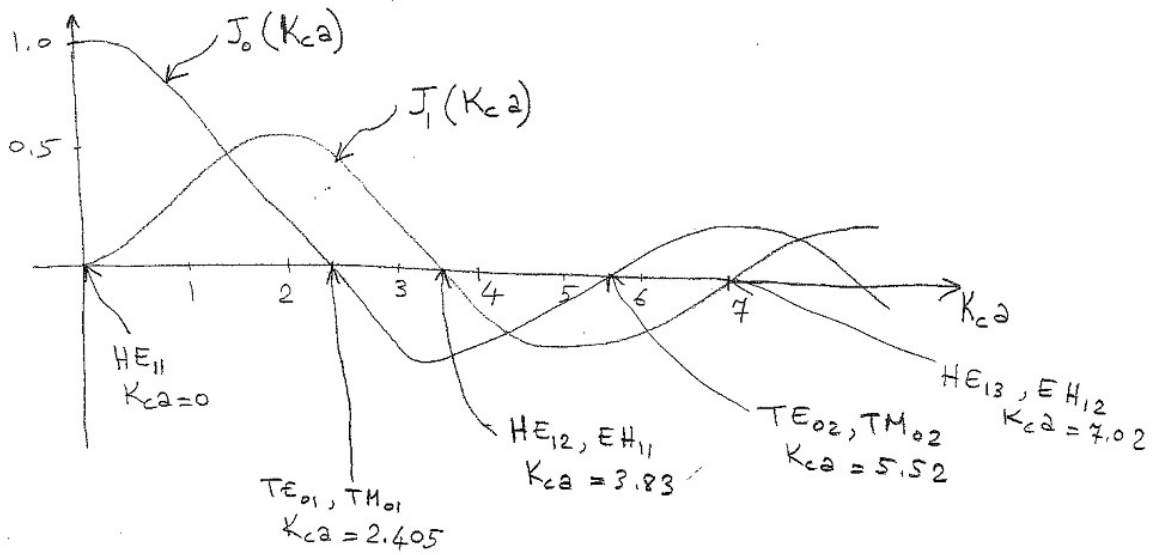

→ HE<sub>vμ</sub> modes for  $v = 2, 3, 4, \dots$

$$\left(\frac{\epsilon_1}{\epsilon_2} + 1\right) J_{v-1}(K_c a) = \frac{a K_c}{v-1} J_v(K_c a)$$

determines the cutoff condition

$N = \#$  of propagating modes

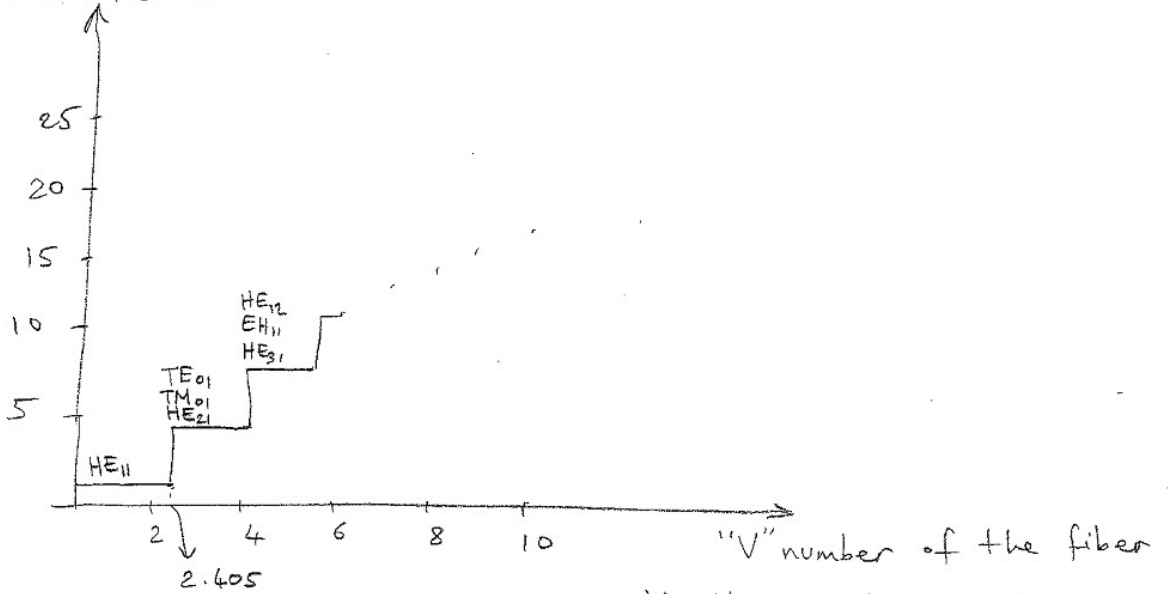

$$V = K_c a = \left(\frac{2\pi}{\lambda_0}\right) a \sqrt{n_1^2 - n_2^2}$$

$$= \frac{2\pi}{\lambda_0} a (NA) \quad \text{if } N \text{ is large}$$

→ If  $V < 2.405$  we have single mode fiber.

→ Total no. of modes ( $N$ ) in a step index fiber ⇒  $N = \frac{4V^2}{\pi^2}$  or  $\sim \frac{V^2}{2}$

## Linearly polarized (LP) modes

→ Assuming  $\Delta = \frac{n_1^2 - n_2^2}{2n_1^2} \ll 1 \implies \Delta \approx \frac{n_1 - n_2}{n_1}$  (weakly guiding fiber)  
 3-dimensional solution is simplified

→ Guided waves propagate at small angles to the fiber axis. Then one can construct modes whose transverse fields are essentially polarized in one direction, i.e.  $E_y, H_x, E_z, H_z$  or  $E_x, H_y, E_z, H_z$ .

→  $LP_{lm}$  modes are actually a superposition of  $HE_{\nu+1, \mu}$  and  $EH_{\nu-1, \mu}$  modes. Here  $l$  refers to a superposition of exact modes with labels  $\nu+1$  and  $\nu-1$ . LP modes are not true modes.

→ Cutoff condition for LP modes

$$J_{l-1}(K_c a) = 0$$

$$\text{For } l=0 \implies J_1(K_c a) = 0$$

$LP_{01}$  corresponds to  $HE_{11}$

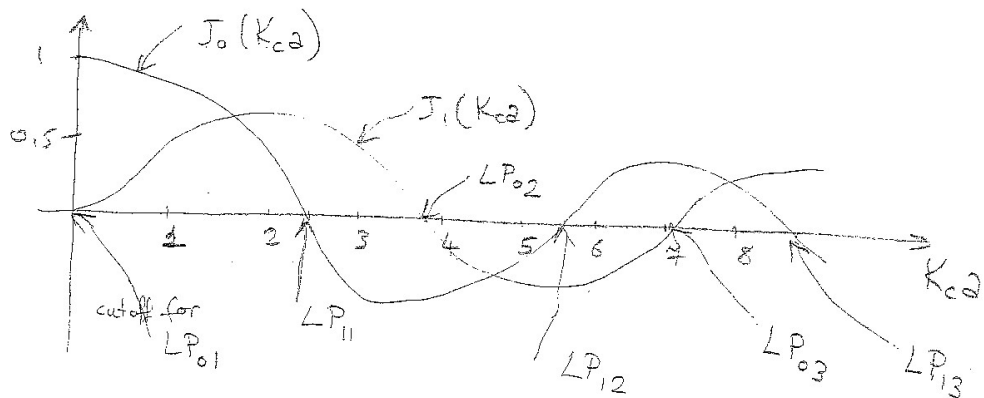

→ Since  $LP_{lm}$  mode is obtained from linear combination of  $HE_{\nu+1, \mu}$  and  $EH_{\nu-1, \mu}$  modes and since each has  $\cos l\phi$  or  $\sin l\phi$  dependence, each  $LP_{lm}$  mode has four discrete HE and EH mode patterns

# Graded Index Fiber

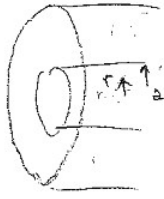

Refractive index profile

$$n(r) = \begin{cases} n_1 \left[ 1 - 2\Delta \left( \frac{r}{a} \right)^\alpha \right]^{1/2} & , r < a \\ n_1 (1 - 2\Delta)^{1/2} & , r > a \end{cases}$$

where  $\Delta = \frac{n_1^2 - n_2^2}{2n_1^2}$

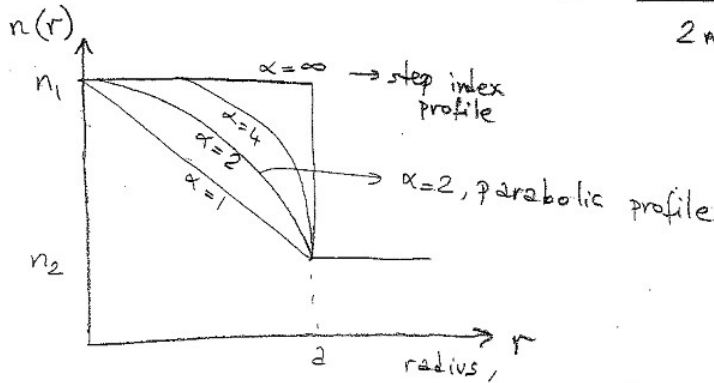

→ Bandwidth of graded index fiber  $\sim 300 \text{ MHz-km} - 3 \text{ GHz-km}$

whereas for step index, bandwidth of the fiber  $< 100 \text{ MHz-km}$ .

## Ray optics analysis of the graded-index fiber

Ray trajectory will be found by solving the ray equation. Without derivation we write the paraxial ray equations as:

$$\frac{d}{dz} \left( r^2 \frac{d\phi}{dz} \right) = \frac{1}{n_1} \frac{\partial n}{\partial \phi} \quad \text{--- (3)}$$

$$\frac{d^2 r}{dz^2} - r \left( \frac{d\phi}{dz} \right)^2 = \frac{1}{n_1} \frac{\partial n}{\partial r} \quad \text{--- (4)}$$

The refractive index does not change with  $\phi$ . Thus  $\frac{\partial n}{\partial \phi} = 0$ . Using this in (3) and integrating

$$r^2 \frac{d\phi}{dz} = c_1 \rightarrow \text{constant} \Rightarrow \frac{d\phi}{dz} = \frac{c_1}{r^2} \quad \text{--- (5)}$$

For  $\Delta \ll 1$

$$n(r) = n_1 \left[ 1 - \left( \frac{r}{a} \right)^2 \Delta \right] \quad \text{--- (6)}$$

$$\frac{\partial n}{\partial r} = -2n_1 \left( \frac{\Delta}{a^2} \right) r \quad \text{--- (7)}$$

Substi (7) and (5) into (4)

$$\frac{d^2 r}{dz^2} + 2 \frac{\Delta}{a^2} r - \frac{c_1^2}{r^3} = 0 \quad \text{--- (8)}$$

Eq. (8) will yield  $r(z)$  as (without showing the intermediate steps,

$$r(z) = A \left\{ 1 + \sqrt{1-b^2} \sin \left[ 2\Omega (z-z_0) \right] \right\}^{1/2} \quad \text{--- (9)}$$

↑  
constant

Using (9) in (5) and integrating we find

$$\phi(z) = \phi_0 + \arctan \frac{1}{b} \left\{ \sqrt{1-b^2} + \tan \left[ \Omega (z-z_0) \right] \right\} \quad \text{--- (10)}$$

↑  
constant

where  $A = \frac{\sqrt{c_3}}{\Omega}$  → constant

$$\Omega = \frac{\sqrt{2\Delta}}{a}$$

$$b^2 = c_1^2 \left( \frac{\Omega}{c_3} \right)^2 \rightarrow \text{check}$$

→  $r(z)$  and  $\phi(z)$  describe the ray trajectory.

→ From (9) it is observed that the ray is trapped inside the fiber core between two turning points  $r_{\max}$  and  $r_{\min}$  given by

$$r_{\max} = A \left( 1 + \sqrt{1-b^2} \right)^{1/2} \quad \text{--- (11)}$$

$$r_{\min} = A \left( 1 - \sqrt{1-b^2} \right)^{1/2} \quad \text{--- (12)}$$

→ The rays spiral down the fiber between  $r_{\max}$  and  $r_{\min}$ .

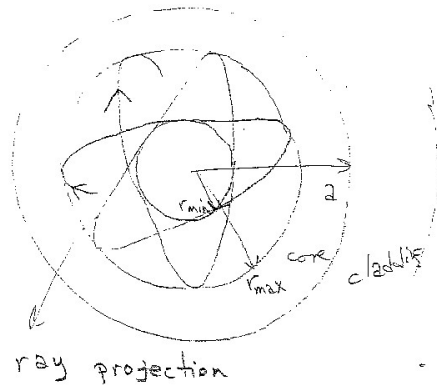

Special cases for (9), (10)

→ For meridional rays  $\phi$  does not change w.r.to.  $z$   
 $\Rightarrow c_1 = 0 \Rightarrow b = 0$ , it can be shown that (9)

$$r(z) = \sqrt{2} A \sin \left[ \Omega(z - z_0) + \frac{\pi}{4} \right] \quad \text{--- (13)}$$

Also for  $b = 0$ , (10) reduces to

$$\phi(z) = \phi_0 + \frac{\pi}{2} \quad \text{--- (14)}$$

, i.e.  $\phi$  is a constant.

(13) and (14) shows that the ray moves on a sinusoidal trajectory in the meridional plane (i.e. passing through the axis) crossing the axis  $r=0$  (meridional ray) as it propagates down the  $z$ -axis. Spatial radian frequency of this sinusoidal meridional ray is  $\Omega$ .

→ The other special case occurs when  $b = 1$

$$r(z) = A \quad \text{--- (15)}$$

$$\phi(z) = \phi_0 + (z - z_0) \Omega \quad \text{--- (16)}$$

This ray described by (15) and (16) is known as the helical ray since the ray travels at a fixed distance from the axis ( $r=A$ ) on a helical path described by (16).

→ Meridional and helical rays are the limiting cases. The general ray will travel along a spiraling trajectory whose distance from the fiber axis varies periodically between the turning

→ Total no. of modes in a graded index fiber is found for the refractive index profile given by ① as

$$N = \frac{V^2}{2} \left( \frac{\alpha}{\alpha + 2} \right) -$$

where  $V = "V" \text{ number} = k_0 a \sqrt{n_1^2 - n_2^2} \approx k_0 a n_1 \sqrt{2\Delta_1}$

and for step index fiber  $\alpha = \infty \Rightarrow N_{\text{step}} = \frac{V^2}{2}$

for parabolic index fiber  $\alpha = 2 \Rightarrow N_{\text{parabolic}} = \frac{V^2}{4}$

$$\text{i.e. } N_{\text{parabolic}} = \frac{N_{\text{step}}}{2}$$

i.e., total no. of modes in a graded index waveguide with a parabolic profile ( $\alpha = 2$ ) is half the no. of modes that exist in a step index fiber.

#### 4. Optical Fiber Communications Link Design

→ Will discuss point-to-point link

##### Procedure

→ Examine the components available for the particular application. The components to choose are:

1. LED or laser diode optical source

- emission wavelength
- spectral line width
- optical output power
- effective radiating area
- emission pattern
- modulation rate

2. Multimode (step or graded index) or single-mode optical fiber

- Core radius
- Core refractive-index profile
- Bandwidth (Dispersion limitation)
- Attenuation
- Numerical Aperture

3. Pin or avalanche photodiode

- Responsivity
- Operating wavelength
- Speed (response time)
- Sensitivity (NEP)

→ See how these components relate to the system performance criteria. System performance requirements are

1. The desired (or possible) transmission distance
2. The data rate or channel bandwidth
3. Bit error rate (BER)

→ For the given set of components and system performance

- Carry out a power budget analysis to



determine whether the link meets the attenuation requirements or if repeaters are needed.

- Carry out a system rise time analysis to verify that the overall system performance requirements are met.
- If performance requirements are not met, change appropriate components and repeat the same procedure.
- Try several designs to find the cheapest design.

### Design Considerations

- Choose the operating wavelength
  - If path length is not long choose 0.8-0.9  $\mu\text{m}$  range
  - If " " " long choose 1.55  $\mu\text{m}$  for low data rates
  - " " " " " " " 1.3  $\mu\text{m}$  " high " "
- Choose the characteristics of two of the main building blocks (transmitter, fiber, receiver) and calculate the characteristics of the remaining third one. Check whether the system requirements are met

### Choosing Photodetector

- Determine the minimum optical power received by the photodetector to satisfy the required bit error rate (BER)
- Keep in mind that:
  - pin photodiode receiver is
    - simpler (cheaper)
    - more stable with temperature changes
    - smaller bias voltage.
  - avalanche photodiodes have → higher sensitivity (ie can detect lower optical power thus increasing the repeater spacing)

### Choosing the Light source

- Parameters to be taken into consideration are: Data rate, transmission distance, cost, dispersion.

— Keep in mind that

LED → is cheaper  
→ no feedback crkt. is needed for temperature stabilization  
→ has longer life time

laser → has narrower spectral width  
→ has higher coupling efficiency (can couple 10-15 dB more power than LED)  
→ is more coherent  
→ has higher modulation rate

LED at 0.8-0.9 $\mu\text{m}$	→	150 (Mb/s) km
LED at 1.3 $\mu\text{m}$	→	> 1.5 (Gb/s) km.
laser at 0.8-0.9	→	2.5 (Gb/s) km
laser " 1.3 $\mu\text{m}$	→	> 25 (Gb/s) km.

### Choosing the Optical Fiber

— Depends on the type of the light source employed and on the maximum amount of dispersion that can be tolerated.

— Check the attenuation characteristics of the fiber and the cabling.

— Check the splice, connector and other losses.

— Keep in mind that

single mode fiber → can be used with laser  
→ yields the maximum bit rate-distance product  
→ has more difficult splicing.

step index multimode fiber → can be used with LED and laser  
→ cheaper  
→ good for low bit rate-distance products.  
→ easier splicing.

graded index fiber → can handle higher bit-rate-distance products as compared to step-index multimode fiber, yet much easier splicing as compared to single mode fiber.

## Link Power Budget

→ Loss in an element =  $10 \log \frac{P_{out}}{P_{in}}$  (dB)

where  $P_{out}$  = output optical power of that specific element  
 $P_{in}$  = input " " " " " "

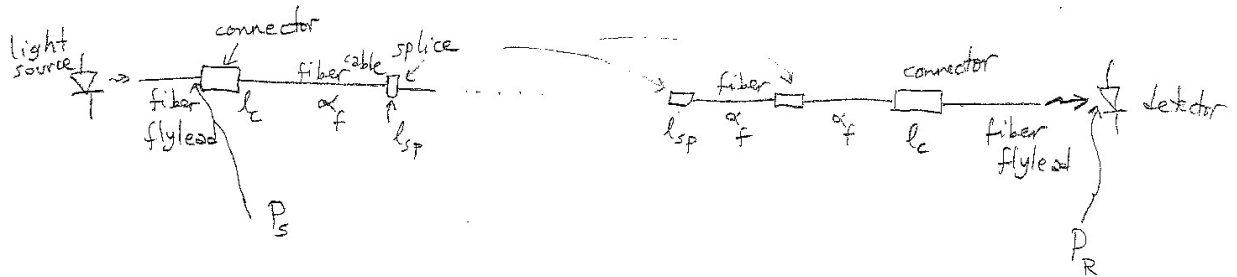

$$P_T = P_S - P_R$$

$P_T$  → total optical power loss  
 $P_S$  → optical power at the end of the fiber flylead attached to source  
 $P_R$  → receiver sensitivity

$$P_T = 2l_c + \alpha_f L + \text{system margin}$$

$2l_c$  → connector loss  
 $\alpha_f L$  → fiber attenuation (dB/km) × transmission distance  
 system margin → ~5-8 dB due to component aging, temp. fluctuation etc.

## Rise Time Budget

→ Performed to determine the dispersion limitation of the fiber link.

$$t_{sys} = \left( t_{tx}^2 + t_{mat}^2 + t_{mod}^2 + t_{rx}^2 \right)^{1/2}$$

$t_{sys}$  → total rise time of the link  
 $t_{tx}$  → the rise time of the transmitter  
 $t_{mat}$  → the material dispersion rise time of the fiber  
 $t_{mod}$  → the modal dispersion rise time  
 $t_{rx}$  → the receiver rise time.

→  $t_{tx}$  results from the rise time of the source and its drive circuitry.

→  $t_{tx}$  can be estimated from Eq. 4-28 of Keiser's book

→  $t_{mat} = D_{mat} \sigma_{\lambda} L$

material dispersion factor  $D_{mat}$  in  $(ns/nm.km)$   
 (can be found from Fig 3-13 of Keiser)

spectral width of the optical source  $\sigma_{\lambda}$

transmission distance  $L$

→  $t_{mod} = \frac{0.44}{B_M} = \frac{0.44 L}{B_0}$

empirical formula

bandwidth in a link of length  $L$

Bandwidth in 1 km. of cable

Here  $B_M = \frac{B_0}{L^2}$

$= 0.5$  for steady state modal equilibrium  
 $= 1$  for little mode mixing  
 $= 0.7$  practical value

→  $t_{mod} = \frac{440 L^2}{B_0}$  (in km)

in nsec

in (MHz)

→  $t_{rx}$  results from the photodetector rise time and the 3dB electric bandwidth of the receiver front end ( $B_{rx}$ )

→  $t_{rx} = \frac{350}{B_{rx}}$

in nsec

empirical formula

$B_{rx}$  (in MHz)

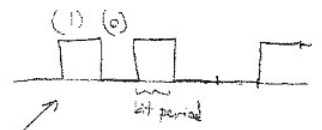

⇒  $t_{sys}$  should be less than  $\left\{ \begin{array}{l} 70\% \text{ of an NRZ (non-return to zero) bit period} \\ 35\% \text{ of an RZ (return-to-zero) bit period} \end{array} \right.$

→ i.e for NRZ if

$t_{sys} < \frac{0.7}{\text{data rate}} \Rightarrow$  design is O.K

if  $t_{sys} > \frac{0.7}{\text{data rate}} \Rightarrow$  try a new design

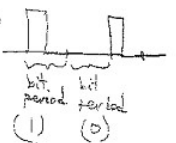

for RZ, replace 0.7 by 0.35

→ Check the cost of the overall system and try other designs to find a cheaper one.

## An example

Perform the power budget and the rise time budget of an optical fiber link with 20 Mb/s data rate (NRZ format) and  $10^{-9}$  bit error rate. Determine the maximum repeaterless transmission distance for the design.

→ Pick a silicon pin photodiode at  $0.85 \mu\text{m}$ .

From Fig. 8-3 of Keiser

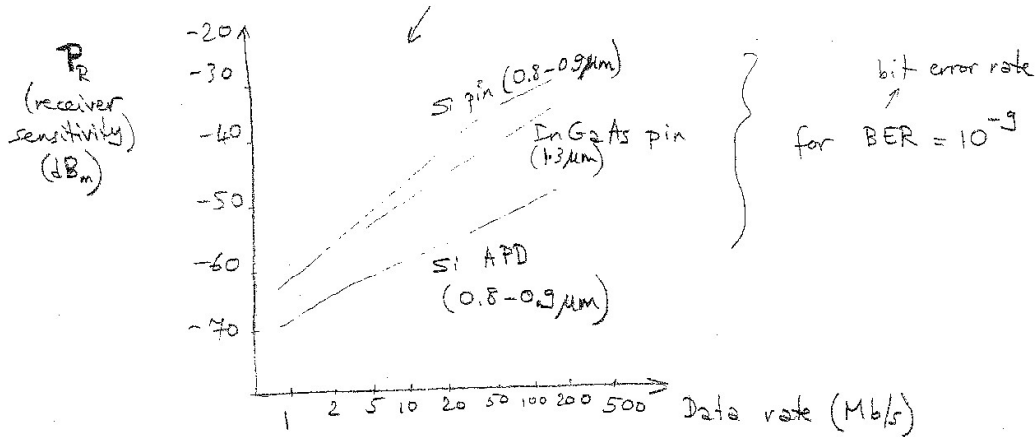

For Si pin photodiode at  $0.85 \mu\text{m}$ ,  $P_R = -42 \text{ dB}_m$  for 20 Mb/s data rate

→ Pick a GaAlAs LED that can couple  $50 \mu\text{W}$  ( $-13 \text{ dB}_m$ ) average optical power into a fiber flylead with  $50 \mu\text{m}$  core diameter. i.e.  $P_S = -13 \text{ dB}_m$

$$\therefore P_T = P_S - P_R = -13 \text{ dB}_m - (-42 \text{ dB}_m) = 29 \text{ dB}_m$$

→ Assume 1 dB loss at the fiber flylead to cable connector and a 6 dB system margin.

$$\therefore 29 \text{ dB} = 2 (1 \text{ dB}) + \alpha_f L + 6 \text{ dB}$$

$$\alpha_f L = 21 \text{ dB}$$

→ If  $\alpha_f = 3.5 \text{ dB/km}$  for the fiber you pick, then

$$L = \frac{21}{3.5} = 6 \text{ km} \Rightarrow \text{This is the repeaterless transmission distance}$$

For graphical representation see Fig. 8-4 of Keiser's book,

For the rise time budget analysis

→ Assume LED and its drive circuitry has  $t_{rx} = 15 \text{ ns}$

→ From Fig. 3-13 of Keiser<sup>or (from 3-27)</sup>  $D_{mat} \cong 87.5 \text{ ps/nm.km}$  at  $\lambda = 0.85 \mu\text{m}$   
 Typical spectral width<sup>(G)</sup> of LED = 40 nm

$$t_{mat} = D_{mat} \sigma_{\lambda} L = 87.5 \text{ ps/nm.km} \times 40 \text{ nm} \times 6 \text{ km}$$

↑  
transmission distance

$$t_{mat} = 21 \text{ nsec.}$$

→ If the fiber selected has 400 MHz.km bandwidth distance product

ie if  $B_0 = 400 \text{ MHz}$

and  $q = 0.7$  for practical values

$$t_{mod} = \frac{440 L^{0.7}}{B_0} \text{ in km} = \frac{440 \times 6^{(0.7)}}{400} \cong 3.9 \text{ nsec.}$$

↑  
in MHz

— For further information on mode coupling effect i.e. the choice of  $q$  read sec. 3-5 of Keiser.

Actually for the first 0.1 – 0.55 km of fiber length  $q \cong 1$ ,  $B_M \times L$   
 " " fiber lengths  $\gg 0.55 \text{ km}$   $q \cong 0.5 \Rightarrow$  mode mixing  $B_M \propto \sqrt{L}$   
 Reasonable estimate for  $q$  is 0.7

→ Assuming the 3dB electric bandwidth of the receiver is  
 $25 \text{ MHz} = \frac{1}{2\pi R_T C_T}$

$$t_{rx} = \frac{350}{25} = 14 \text{ ns}$$

$$\therefore t_{sys} = \left[ (15 \text{ ns})^2 + (21 \text{ ns})^2 + (3.9 \text{ ns})^2 + (14 \text{ ns})^2 \right]^{1/2}$$

$$\cong 29.6 \text{ ns}$$

$$\rightarrow \frac{0.7}{\text{data rate}} = \frac{0.7}{20 \text{ Mb/s}} = 35 \text{ ns}$$

$$t_{sys} = 29.6 \text{ ns} < 35 \text{ ns}$$

$\therefore$  the design is O.K based on rise time budget

→ Check the cost of the overall system and try other designs

## 5. Attenuation in Optical Fibers, Power Budget Analysis

1. Attenuation, i.e. power loss in fibers
  - Absorption losses
  - Scattering losses
  - Radiative losses (Bending, microbending, waveguide losses)
2. Dispersion, i.e. broadening of a pulse at the receiving end of the fiber
  - Intramodal dispersion
    - Material dispersion
    - Waveguide dispersion
  - Intermodal dispersion.

---

### Attenuation

→ Determines the maximum distance between a transmitter and a receiver.

→ Signal attenuation is defined as

$$\alpha = [10 \log(P_{in}/P_{out})] / L \quad \text{dB/km.}$$

$$\text{No loss} \Rightarrow P_{out} = P_{in} \Rightarrow \alpha = 0 \text{ dB/km.}$$

→ Actual fiber has in the order of several dB/km loss, 0.2 dB/km or even less reported to be feasible.

### Absorption

Light is absorbed within the fiber by 3 different mechanisms:

1. By atomic defects in the glass composition

Atomic defects are imperfections of the atomic structure of the fiber such as missing molecules, high-density clusters of atom groups or oxygen defects in the glass structure.

→ Attenuation due to atomic effects is not significant in general.

However, it could be important if the fiber is exposed to intense nuclear radiation levels.

2. Extrinsic absorption by impurity atoms in the glass material.

This is the dominant absorption factor in fibers (prepared by direct melt method)

→ Impurity absorption results from ions such as iron, chromium, cobalt, copper and OH (water)

ions. Occur from electronic transitions between energy levels associated with the incompletely filled inner subshell of these ions or from charge transitions from one ion to another

→ Metal impurities present in the fiber is  $\sim 1$  or  $10$  parts in  $10^9$  (changes depending on the fiber fabrication method). Causes  $1$  to  $10$  dB/km loss.

→ OH (hydroxyl) ion impurities in fiber preforms results from the oxyhydrogen flame used for the hydrolysis reaction of the  $\text{SiCl}_4$ ,  $\text{GeCl}_4$  and  $\text{POCl}_3$  starting materials.

→ OH concentration should be less than  $1$  in  $10^9$  parts for attenuation to be less than  $20$  dB/k

Large absorption peaks at  $1400$ ,  $950$  and  $725$  nm

Between these peaks there are regions of low attenuation.

3. Intrinsic absorption by the basic constituent atoms of the fiber material.

→ Results from electronic absorption bands in the ultraviolet region and from atomic vibration bands in the near-infrared region.

### Scattering

Results from microscopic variations in the material density, from compositional fluctuations or from structural inhomogeneities or defects occurring during manufacturing of the fiber.

→ Glass, being composed of randomly connected molecules, contains regions in which the molecular

density is either higher or lower than the average density in glass.

→ Also glass has several oxides as  $\text{SiO}_2$ ,  $\text{GeO}_2$ ,  $\text{P}_2\text{O}_5$  so compositional fluctuations can occur.

→ As a result of these two effects  $n$  varies within glass over distances that are small compared to wavelength.

→ Result is Rayleigh scattering (as in molecular scattering in the atmosphere).

→ Rayleigh scattering has  $\lambda^{-4}$ , i.e.  $f^4$  dependence. It increases dramatically as frequency increases. For  $\lambda < 1\mu\text{m}$ , Rayleigh scat. is the dominant loss in fibers. At  $\lambda > 1\mu\text{m}$ , infrared absorption effects tend to dominate optical signal attenuation.

### Radiative losses

#### → Bending losses

Losses due to bends in fiber having radii that are large compared to the fiber diameter, e.g. when fiber cable turns a corner. As the radius of curvature decreases, loss  $\uparrow$  exponentially. It is negligible up to a critical  $R = R_c \equiv \frac{a}{(NA)^2} = \frac{a}{n_1^2 - n_2^2}$

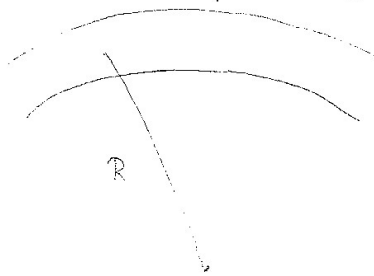

If  $R > R_c$ , loss is considerable (some of the light is not totally internally reflected but propagates into the cladding and is radiated away)

→ Even for  $R > R_c$ , the limiting factor is the mechanical properties of the fiber, i.e. a mechanically acceptable (no significant stress cracking) bending radius gives rise to negligible bending loss.

→ Microbending losses - Due to microbends which are known as the repetitive changes in the radius of curvature of the fiber axis. Microbends are caused by either nonuniformities in the sheathing of the fiber or by nonuniform lateral pressures created during the cabling of the fiber (also known as the cabling or packaging losses)

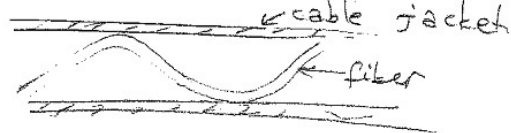

or Unsheathed fiber wound on a drum.

→ Microbends cause repetitive coupling of energy between the guided and the leaky or nonguided modes in the fiber.

→ Microbending losses is minimized by extruding a compressible jacket over the fiber

### Waveguide losses

Continuous, small variations in core diameter, which can easily arise during manufacture, may give rise to scattering known as waveguide losses.

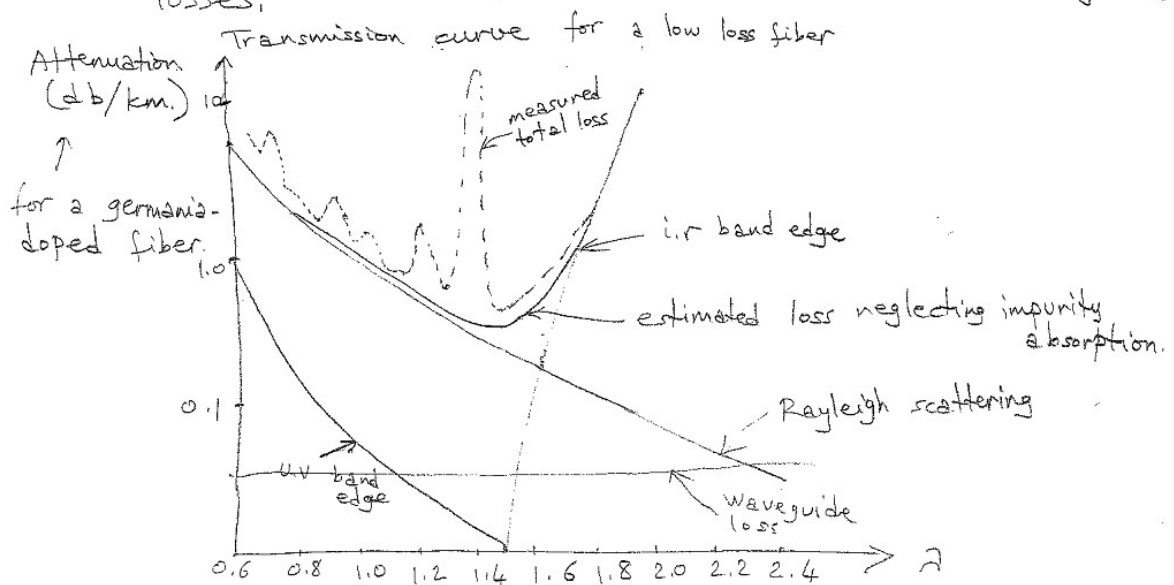

→ This curve may differ for different type of dopants

Transmission windows (lowest attenuation at  $\lambda = 1.55 \mu\text{m}$  for Germania-doped silica,  $1.3 \mu\text{m}$  has low attenuation, too.

## 6. Dispersion in Optical Fiber Communications

### Dispersion in Optical Fibers

Dispersion is the phenomenon that each frequency component will travel with different velocity due to the fact that the refractive index of the medium is a function of the wavelength.

Dispersion results in the broadening of the light pulse. This pulse broadening causes a pulse to overlap with the neighboring pulses. After a certain amount of overlap has occurred, adjacent pulses can no longer be individually distinguished at the receiver and errors will occur. Thus dispersion properties determine the limit of the information capacity of the fiber.

In step index (multimode)  $\sim 20 \text{ MHz} \cdot \text{km}$ .

In graded index (at specific wavelength)  $\sim 2.5 \text{ GHz} \cdot \text{km}$ .

In single-mode fiber  $\sim > 2.5 \text{ GHz} \cdot \text{km}$ .

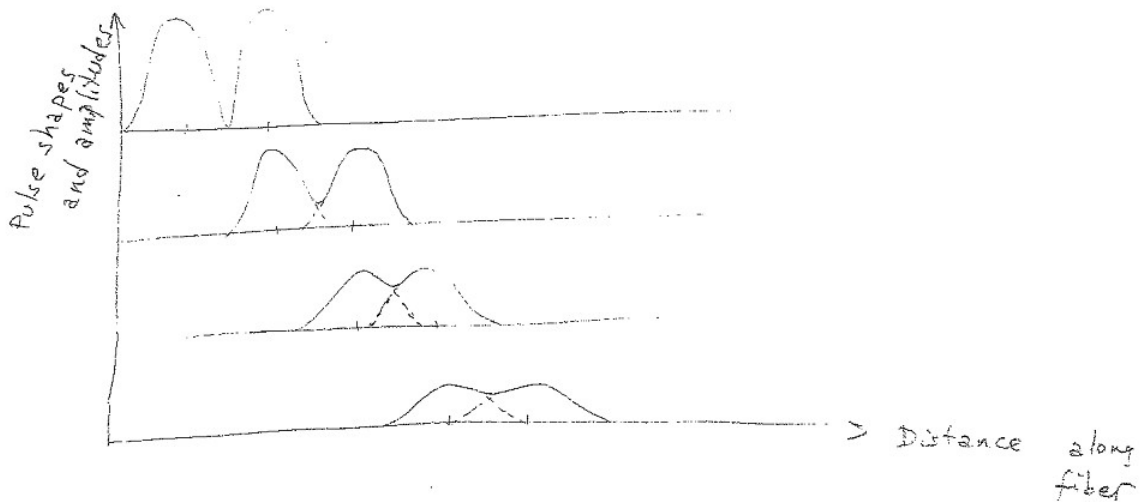

→ As a background let us study group velocity

For monochromatic wave having only  $y$ -comp. and propagating in  $z$ -direction in a dielectric medium

$$E_y = A \cos(\omega t - kz)$$

$$\text{setting phase = constant} \Rightarrow \omega t - kz = \text{const}$$

$$\omega = \frac{dz}{dt} = \frac{\omega}{k} \Rightarrow \text{known as the phase velocity}$$

If the wave has two frequencies;  $\omega + \Delta\omega \Rightarrow k + \Delta k$   
 $\omega - \Delta\omega \Rightarrow k - \Delta k$

$$E_y = E_y^1 + E_y^2 = A \left\{ \cos [(\omega + \Delta\omega)t - (k + \Delta k)z] + \cos [(\omega - \Delta\omega)t - (k - \Delta k)z] \right\}$$

$$E_y = 2A \cos(\omega t - kz) \underbrace{\cos(\Delta\omega t - \Delta k z)}_{\text{slowly varying envelope of the carrier}} \rightarrow \text{like AM wave}$$

$v_g$  = group velocity is obtained by setting

$$\Delta\omega t - \Delta k z = \text{const.}$$

and  $v_g = \frac{dz}{dt} = \frac{\Delta\omega}{\Delta k}$

In the limit  $\Delta\omega \rightarrow 0$

$$v_g = \frac{d\omega}{dk} = c \left( \frac{d\beta}{dk} \right)^{-1}$$

→  $v_g$  is actually the phase velocity of the wave envelope and the velocity that information modulated on a wave will propagate at.

→ Examine the case that a signal modulates an optical source

→ Assume that the modulated optical signal excites all modes equally at the input of the fiber. i.e. each mode carries an equal amount of energy through the fiber.

→ Each mode contains all of the spectral components in the wavelength band over which the source emits.

→ The signal may be considered as modulating each of these spectral components in the same way. As the signal propagates along the fiber, each spectral component can be assumed to travel independently and to undergo a time delay or group delay in the direction of propagation given by

$$t_g = \frac{L}{v_g} = \frac{L}{c} \frac{d\beta}{dk} = -\frac{\lambda^2 L}{2\pi c} \frac{d\beta}{d\lambda} \quad (1)$$

Pulse spread (total delay difference over a distance  $L$ )

$$\sigma_g = \frac{dt_g}{d\lambda} \sigma_\lambda \quad \text{--- (2)}$$

where  $\sigma_\lambda \rightarrow$  r.m.s spectral width  $\Delta\lambda$

$\frac{dt_g}{d\lambda} \rightarrow$  delay difference per unit wavelength.

### Material dispersion

$\rightarrow$  Due to  $n$  being a function of  $\lambda \Rightarrow \beta = \frac{2\pi}{\lambda} n(\lambda)$

$\rightarrow$  Important for single mode waveguide

$\rightarrow$  " " LED systems (since LED has broader spectrum than Laser diode)

Group delay resulting from material dispersion

$$t_{\text{mat.}} = \frac{-\lambda^2 L}{2\pi c} \left[ n \left( -\frac{2\pi}{\lambda^2} \right) + \frac{2\pi}{\lambda} \frac{dn}{d\lambda} \right]$$

$$= \frac{L}{c} \left[ n - \lambda \frac{dn}{d\lambda} \right] = \frac{L}{c} N_g$$

$N_g =$  group index

The pulse spread due to material dispersion  $\sigma_{\text{mat}}$  is

$$\sigma_{\text{mat}} = \frac{dt_{\text{mat}}}{d\lambda} \sigma_\lambda = -\frac{L \sigma_\lambda}{c} \left[ \frac{dn}{d\lambda} - \lambda \frac{d^2n}{d\lambda^2} - \frac{dn}{d\lambda} \right]$$

$$\sigma_{\text{mat}} = -\frac{L \sigma_\lambda}{c} \lambda \frac{d^2n}{d\lambda^2}$$

Take || if  $\sigma_{\text{mat}} < 0$   
absolute

$\sigma_{\text{mat}}$  for silica  
per unit length  
and unit optical  
source spectral  
width.

[ps/(nm-km)]

↑  
picosecond

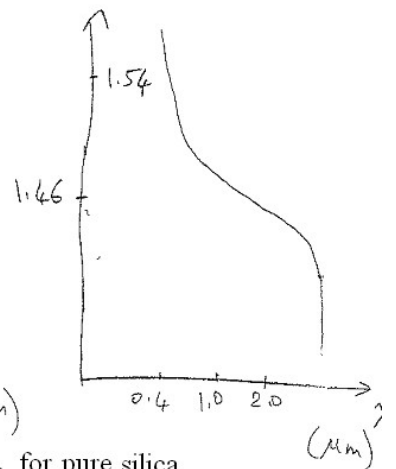
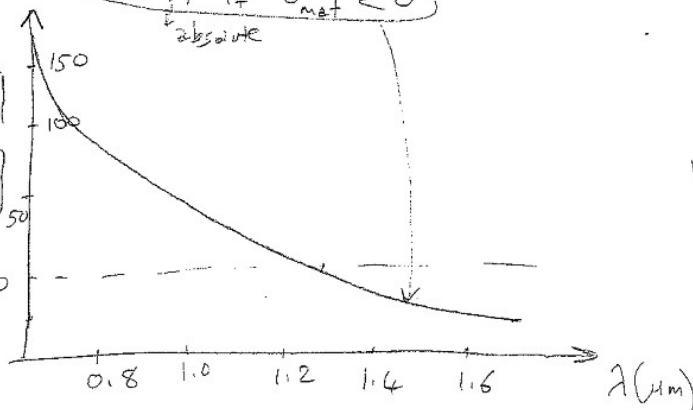

$\rightarrow$  Material dispersion  $\rightarrow 0$  at  $1.27 \mu\text{m}$  for pure silica

# Waveguide dispersion

Is due to the explicit dependence of  $\beta$  on  $\omega$   
 i.e.  $\beta = \frac{\omega}{c} n$ , i.e.  $\beta$  varies with  $\omega$  even though there is no material dispersion (i.e.  $n \neq n(\omega)$ )

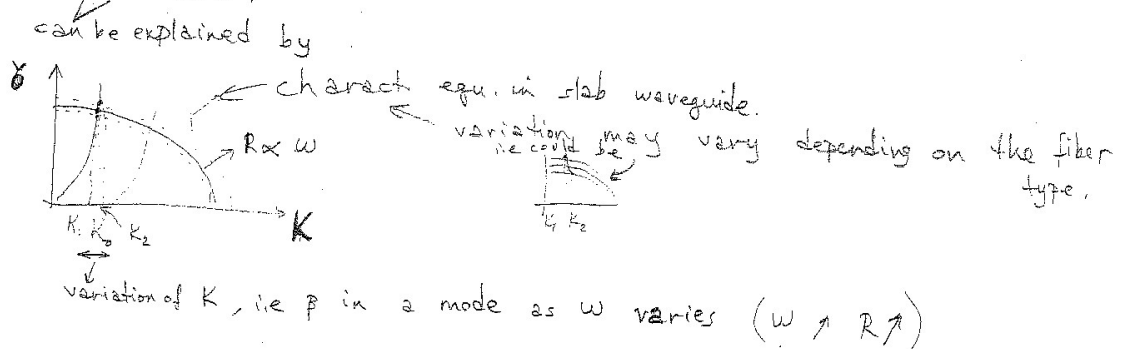
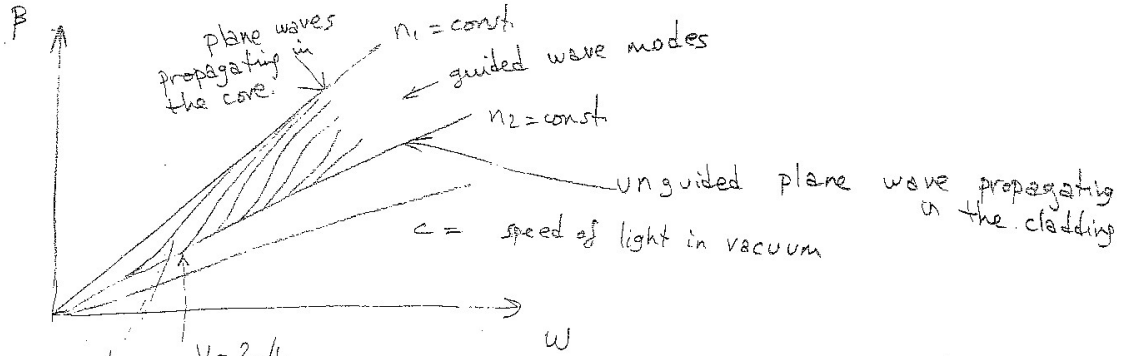

→ without derivation pulse spread due to waveguide dispersion is:

$$\sigma_{wg} = -\frac{n_2 L A \sigma_\lambda}{c \lambda} V \frac{d^2(Vb)}{dV^2}$$

where  $b = \frac{\beta/k - n_2}{n_1 - n_2}$

→ At longer wavelengths  $\lambda > 1.3 \mu\text{m}$ , waveguide dispersion  
 At shorter " "  $\lambda < 1.3 \mu\text{m}$ , material " "

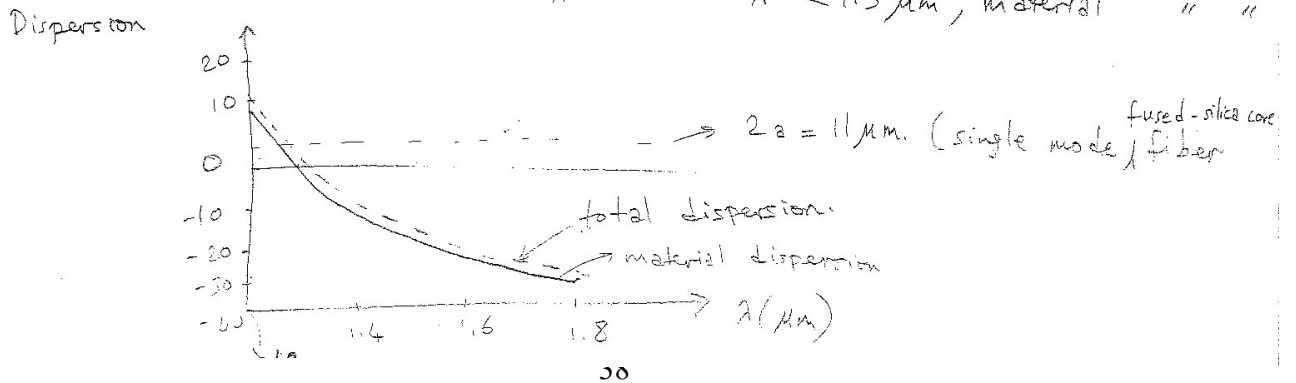

## Intermodal Dispersion

Due to the delays occurring between the different modes. In step index fiber

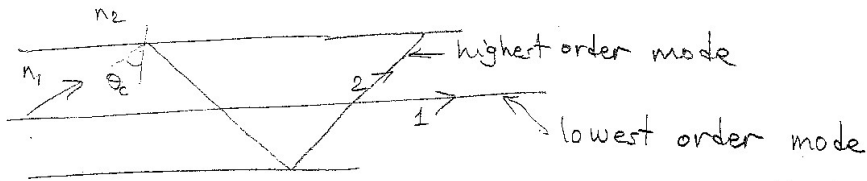

$$\tau_{\text{mod}} = T_{\text{max}} - T_{\text{min}} = \frac{L}{c} N_{g1} - \frac{L}{c} N_{g2}$$

↑ arrival time of highest order mode     
 ↑ arrival time of lowest order mode

↑ group refractive index of ray 1     
 ↑ group ref. ind. of ray 2

where  $N_g = n - \lambda \frac{dn}{d\lambda}$

If no mat. disp.  $N_g = n$

$$\therefore \tau_{\text{mod}} = \frac{L}{c} (n_1 - n_2)$$

- $\tau_{\text{mod}}$  dominates pulse spreading in step index fibers.
- Relative dominance of  $\tau_{\text{mod}}$  is greater for laser

→ Total rms pulse broadening can be found as

$$\sigma = (\sigma_{\text{intermodal}}^2 + \sigma_{\text{intramodal}}^2)^{1/2}$$

where  $\sigma_{\text{intermodal}} = (\langle \tau_g^2 \rangle - \langle \tau_g \rangle^2)^{1/2}$

$$\sigma_{\text{intramodal}}^2 = L^2 \left( \frac{\sigma_\lambda^2}{\lambda} \right) \left\langle \left( \lambda \frac{dN_g}{d\lambda} \right)^2 \right\rangle$$

## Dispersion in graded index fibers

$\alpha = 2$ , i.e. parabolic profile is optimum for low dispersion in graded index fibers.

- Low dispersion  $\Rightarrow$  high data rate over long distances possible
- Large core still low dispersion (single-mode fibers have low dispersion too, however core is very small, i.e. difficulty in splicing)

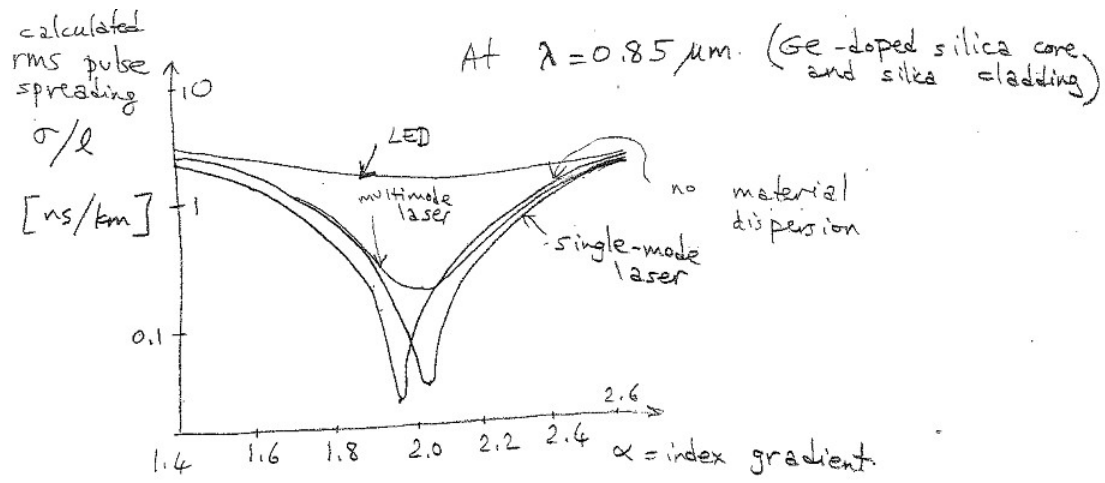

### Optimum Wavelength for Silica Fibers

Here we plot the optimum wavelength curves where the system parameters are the bandwidth and repeater spacing, the fiber properties that determine these system parameters are dispersion and attenuation.

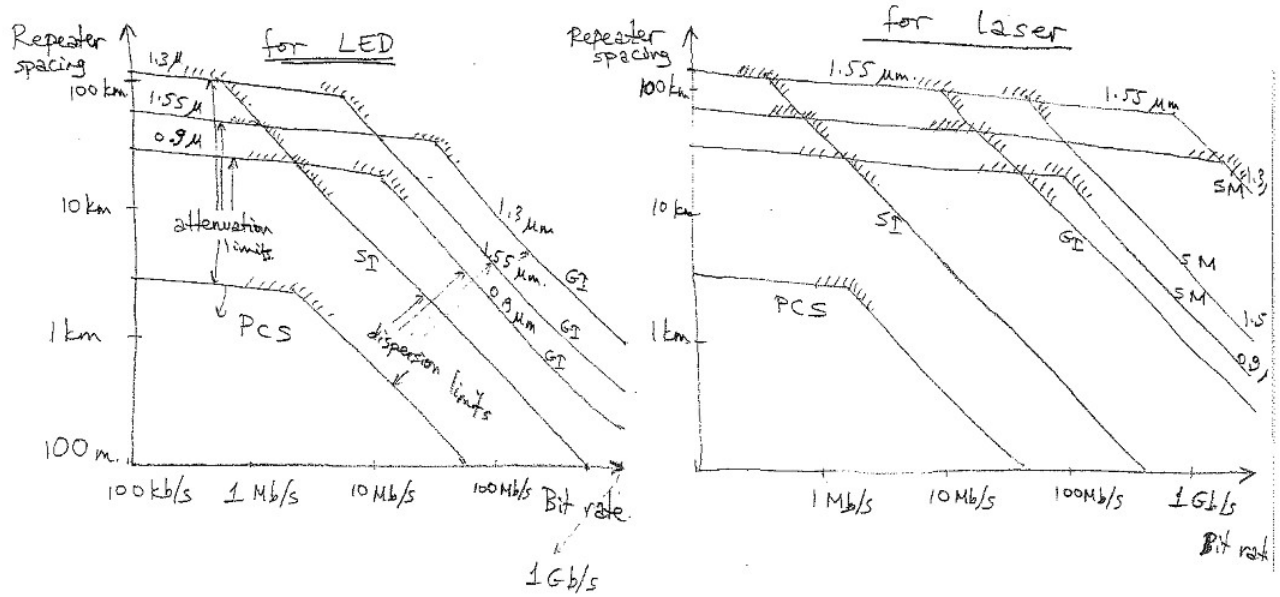

- PCS = polymer clad - silica
- SI = step index
- GI = graded index
- SM = single mode fiber

Attenuation is the limiting factor for low data rates, dispersion is the limiting factor for high data rates.

## 7. Optical Sources and Detectors used in Optical Fiber Systems

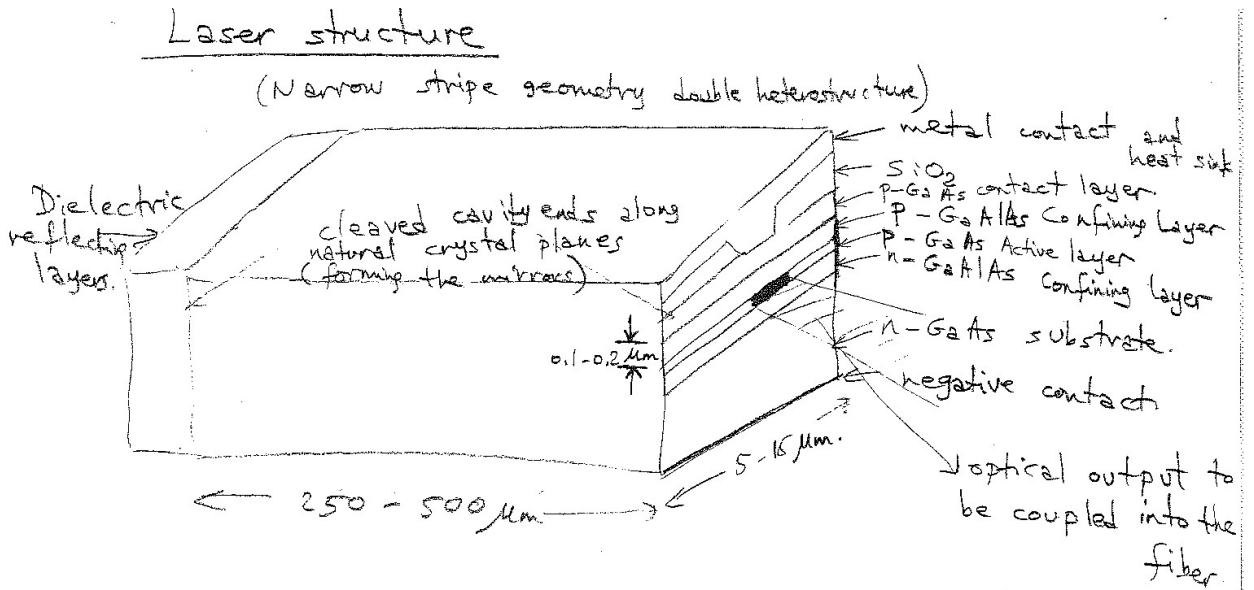

- Fabry-Perot resonator cavity (supports specific modes)
- Distributed feedback (corrugated feedback grating) no mirrors.

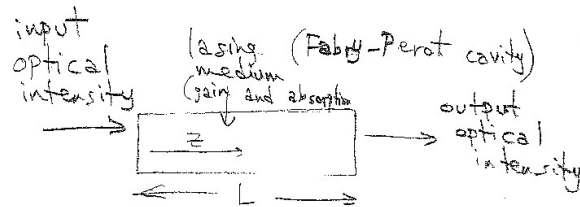

$$I(z) = I(0) \exp \left\{ [g(hf) - \alpha(hf)] z \right\}$$

↙ optical field intensity
↖ gain of the Fabry-Perot cavity
↗ absorption coefficient

- Optical amplification of the selected modes is provided by the feedback in the cavity.
- In each pass between the partially reflecting mirrors the optical intensity of the selected modes is amplified.

→ When the gain of the selected modes is sufficient to exceed the optical loss during one round trip in the cavity, lasing occurs. For the round trip

$$I(2L) = I(0) R_1 R_2 \exp\{2L [g(hf) - \alpha(hf)]\}$$

$\uparrow$  reflectivity of mirror 1       $\uparrow$  reflectivity of mirror 2

→ At the lasing threshold  $I(2L) = I(0) \Rightarrow$  i.e. it behaves as an oscillator

$$\Rightarrow g_{th} = (2L)^{-1} \ln[(R_1 R_2)^{-1}] + \alpha$$

$\uparrow$  gain at threshold ( $cm^{-1}$ )

Threshold current density  $J_{th}$  is  $\left( \frac{i_{th}}{A} = J_{th} \right)$  current  
Junction Area

$$J_{th} = \frac{8\pi q d \Delta f n^2}{\lambda^2 \eta_i} g_{th} \quad \left( \frac{Amp}{m^2} \right)$$

where  $d$  = thickness of the mode confinement volume

$n$  = refractive index

$\eta_i$  = internal quantum efficiency

$\Delta f$  = transition linewidth

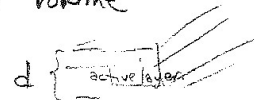

offer output power of semiconductor lasers

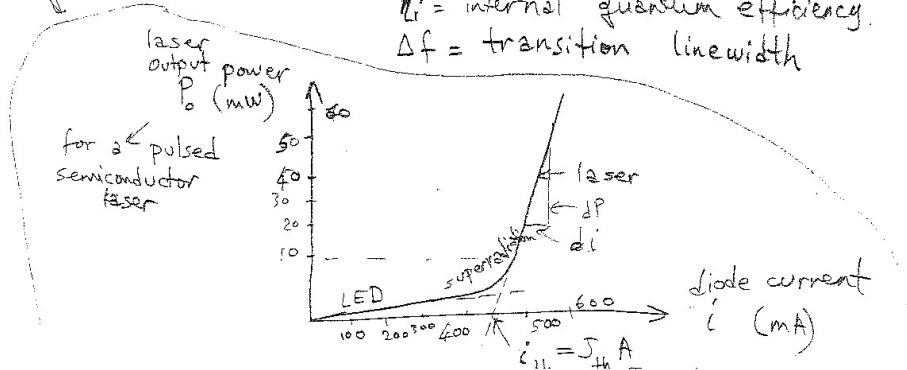

## Output Power of Semiconductor Lasers

As injection current is increased above threshold, laser oscillations build up and the resulting stimulated emission reduces the population inversion until it is clamped at the threshold value. <sup>in injection current above threshold will not increase the gain anymore but</sup> Then power <sup>will increase the output power emitted by stimulated emission is</sup>

$$P = \underset{\substack{\uparrow \\ \text{junction} \\ \text{area}}}{A} (J - J_{th}) \frac{\eta_i \cdot hf}{q} \rightarrow E_g$$

charge of electron

$\frac{E_g \eta_i}{\text{unit time}} = \text{Power}$

$\frac{(J - J_{th}) A \cdot hf}{q}$

Part of this power is dissipated <sup>(proportional to  $\alpha$ )</sup> in the laser cavity and the rest is coupled via the end mirrors (proportional to  $(2L)^{-1} \ln[(R_1 R_2)^{-1}]$ ).

∴ Output power is

$$P_o = \frac{A [J - J_{th}] \cdot hf}{q} \frac{\left[ \frac{1}{2L} \ln \left( \frac{1}{R_1 R_2} \right) \right]}{\left[ \alpha + \frac{1}{2L} \ln \left( \frac{1}{R_1 R_2} \right) \right]} \eta_i$$

→ Plot on p. 63

→ External quantum efficiency  $\eta_{ext}$ .

$$\eta_{ext} = \frac{\# \text{ emitted photons}}{\# \text{ electron-hole pair recombination above threshold}}$$

$$\eta_{ext} = \frac{q}{E_g} \left( \frac{dP}{di} \right) \overset{\text{- slope above threshold.}}{=} 0.8065 \lambda \text{ (}\mu\text{m)} \frac{dP \text{ (mW)}}{di \text{ (mA)}}$$

$\eta_{ext} = 0.3 - 0.4$  for semiconductor lasers.

# Modal Properties of semiconductor lasers

- Transverse modes (spatial modes) depend on the geometry of the optical resonator. Determines the directivity of the laser beam. Each transverse mode has different beam intensity distribution.

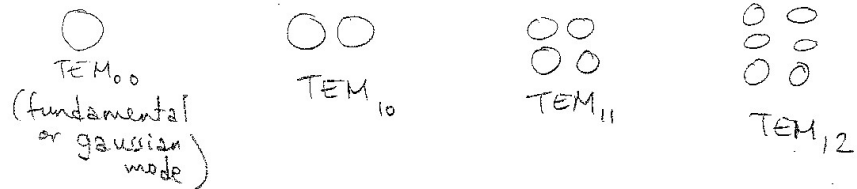

- Longitudinal modes (axial modes) - Due to standing wave patterns formed in the longitudinal direction inside the resonator

$$k(2L) = \nu 2\pi \implies \underbrace{k}_{\substack{\uparrow \\ \text{Prop. constant} \\ \text{phase}}} \underbrace{(2L)}_{\substack{\uparrow \\ \text{distance for round trip}}} = \underbrace{\nu}_{\substack{\uparrow \\ \text{refractive index}}} \underbrace{2\pi f}_{\substack{\uparrow \\ \text{refractive index}}} \underbrace{2L}_{\substack{\uparrow \\ \text{refractive index}}} = \nu 2\pi$$

$\nu = 0, 1, 2, \dots$

$$\implies f = \nu \frac{c}{2Ln}$$

$f$ : frequency of oscillation number  
 $\nu$ : axial mode  
 $2Ln$ : refractive index mirror separation (resonator length)

$\nu$  may be large, its exact value is not important.

$\Delta f$  = frequency separation between axial modes

$$\Delta f = (\nu+1) \frac{c}{2Ln} - \nu \frac{c}{2Ln} = \frac{c}{2Ln}$$

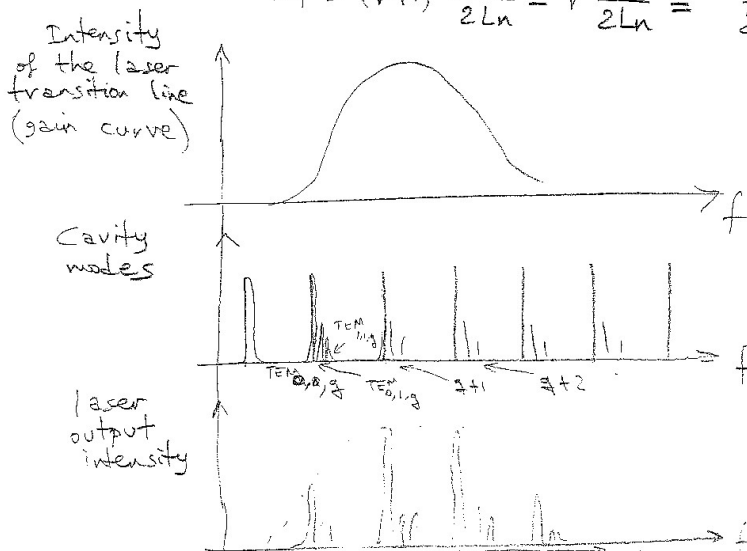

→ By reducing the cavity length  $L$ ,  $\Delta f \uparrow$  so that one can obtain single mode operation.

→ As thickness of optical cavity  $\uparrow$  transverse beam width  $\downarrow$  but  $J_{th} \uparrow$  so a tradeoff is necessary

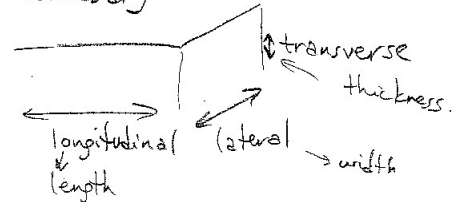

For cw laser diodes  $\theta_{\perp}$  (transverse beam width)  $\approx 30 - 50^{\circ}$   
 $\theta_{\parallel}$  (lateral beam width)  $\approx 5 - 10^{\circ}$   
 $\nearrow$  to pn junction plane

→ Spectral output of a semiconductor laser at different current levels.

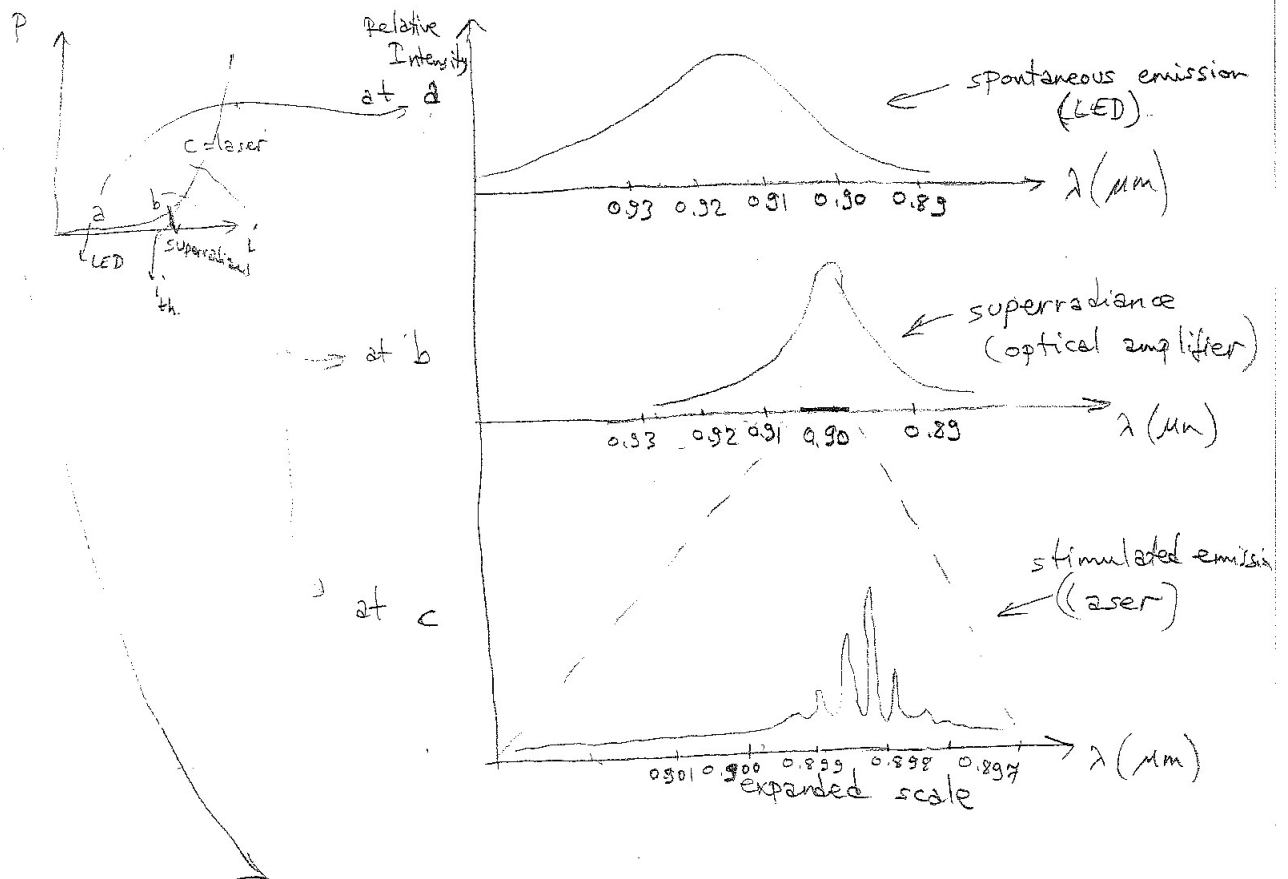

→ Modulation of Laser diodes

$\tau_{ph}$  = photon lifetime = average time the photon stays in the cavity before being lost either by absorption or by emission.

$\Delta\omega$  = modulation bandwidth of laser  $\propto \frac{1}{\tau_{ph}} = \frac{c}{n} g_{th}$

Since  $g_{th} \uparrow \Rightarrow J_{th} \uparrow$

As  $J_{th} \uparrow$ ,  $\Delta\omega \uparrow$  however  $J_{th} \uparrow$  lifetime  $\downarrow$

→ In pulse modulation delay time ( $t_d$ ) limits the modulation rate.

$t_d = \tau \ln \frac{i_p}{i_p + (i_b - i_{th})}$

Labels:  $i_p$  ← pulse current amplitude;  $i_b$  ← bias current;  $i_{th}$  ← threshold current

↑ average lifetime of carriers in the recombination region when  $i = i_p + i_b$  is close to  $i_{th}$ .

If the laser is completely turned off after each pulse, on the onset of a current pulse, a period  $t_d$  is needed to achieve population inversion necessary to produce a gain that is sufficient to overcome the optical losses in the cavity.

→  $t_d$  is eliminated by choosing  $i_b = i_{th}$ .  
 ↑ d.c bias current

→ For analog modulation

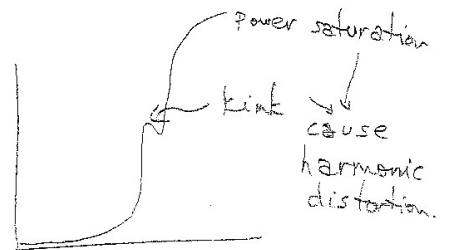
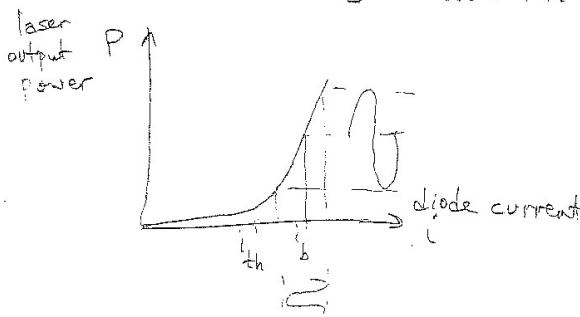

→ Temperature effects

Threshold current depends on temperature. Thus a feedback is needed in laser drive circuitry to stabilize the laser output. i.e. if a constant optical power level is needed as the temperature of the laser changes or as the laser ages, it is necessary to adjust the dc bias current.

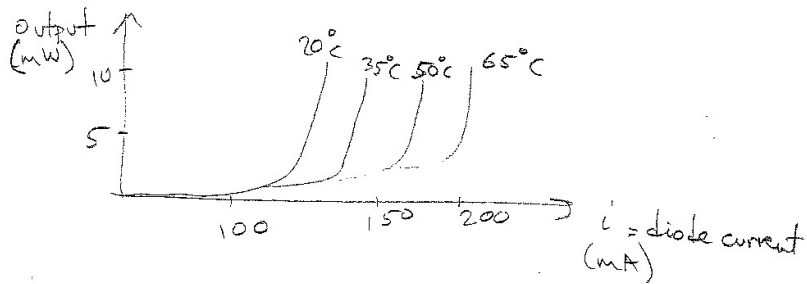

→ Reliability - Operating lifetime ( $\bar{G}_s$ )  $\propto J^{-n}$ ,  $1.5 \leq n < 2.0$

→ As  $J \uparrow$ ,  $\bar{G}_s \downarrow$   
 → As  $T_{eng} \uparrow$ ,  $\bar{G}_s \downarrow$

laser lifetime also depends on facet degradation. (could be catastrophic due to mechanical damage to facets or could erode during some time.)

→ Comparison of LED and laser diode performance

	DLDS	LEDs
Feedback (stabilize laser or bias)	required	not required
Bandwidth of the source (rms)	2-4 nm	15-60 nm
output power	1-10 mW	1-10 mW
power launched into fiber	0.5-5 mW	0.03-0.3 mW
Rise time, 10-90%	$\leq 1$ ns	2-20 ns
Modulation bandwidth (3db)	$> 500$ MHz	$< 200$ MHz
Forward current	10-300 mA	50-300 mA
Threshold current	5-250 mA	not required
Source coherence property	more coherent	more incoherent
emitting sizes	5-15 $\mu$ m wide 0.1-0.2 $\mu$ m thick	circular 50 $\mu$ m in diameter (surface emitter) 50-70 $\mu$ m (edge emitter)
emission pattern	$\theta_{\perp} = 30-50^{\circ}$ $\theta_{\parallel} = 5-10^{\circ}$	isotropic with $120^{\circ}$ half power beamwidth (surface emitter) $\theta_{\parallel} = 120^{\circ}$ , $\theta_{\perp} = 30^{\circ}$ (edge emitter)
cost	expensive	cheap

$\theta_{\perp} \Rightarrow$  transverse  
 $\theta_{\parallel} \Rightarrow$  lateral  
 beamwidth  $\rightarrow$  Lambertian  
 $\perp$  to pn junction plane  
 " " " " " "

# Photodetectors

- Converts optical power into electric current
- For optical fiber systems mostly used detectors are the semiconductor pin photodetector and avalanche photodiode (APD).
- Requirements for a good detector
  - high sensitivity (should be able to detect as low power as possible before the noise factor starts to limit the performance), i.e. low NEP (noise equivalent power)
  - (This sensitivity should be at the wavelength of operation of the source)
  - speed (should be fast enough, i.e. should have large enough bandwidth to follow the data rate being used).
  - minimum addition of noise to system
  - low cost and long life time
  - compatible size to optical fiber dimensions.
  - insensitive to temperature variations.

## Pin photodetector

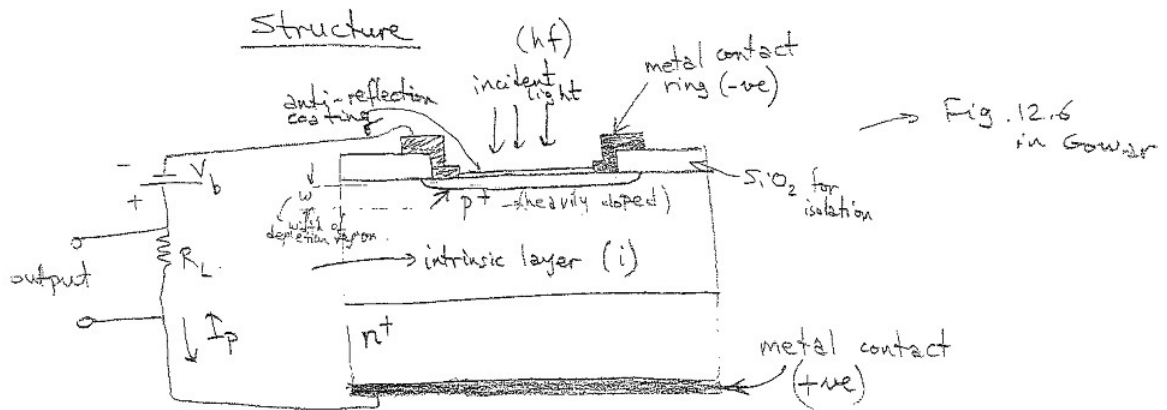

## Operation

- large reverse bias is applied (to improve speed and efficiency) ⇒ intrinsic region is fully depleted of carriers (intrinsic  $n_i$  and  $p$  carrier concentration << impurity concentration in (i) region)

- Incident photon of energy  $\geq E_g$  of the semiconductor material strikes the p-type material
- Incident photon excites an electron from the valence band to conduction band, generating electron-hole pairs.
- High reverse bias separates the electron-hole pairs and collects them across the reverse-biased junction, causing the photocurrent flow through the external circuit.

→ The average photocurrent  $I_p$ , generated by a steady state average optical power  $P_0$  is given by

$$I_p = q \cdot (\# \text{ of electron-hole pairs})$$

↑  
- electron charge

$$\# \text{ of electron-hole pairs} = \frac{\text{Power absorbed in the depletion region}}{E_g = \text{photon energy}} \times \left( \text{fraction of the reflected power} \right)$$

$$= \frac{P_0 (1 - e^{-\alpha_s(\lambda) w})}{hf} \times (1 - R_f)$$

here  $w$  = width of the depletion region  
 $R_f$  = reflectivity of the entrance face of the photodiode (anti-reflection coating)  
 $\alpha_s(\lambda)$  = absorption coefficient of the semiconductor material

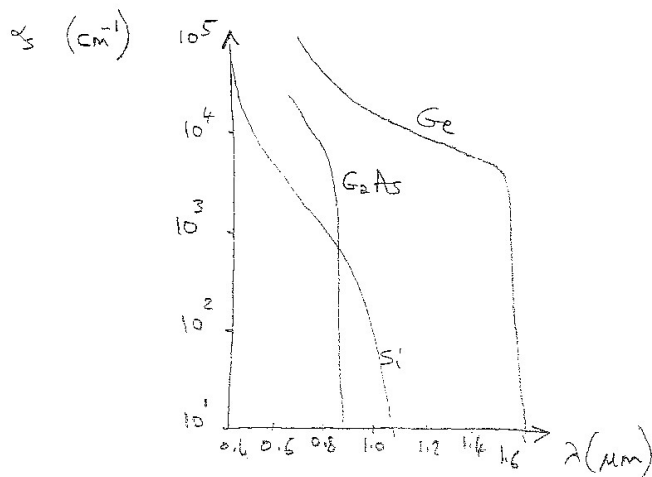

$$I_p = \frac{q}{hf} P_0 (1 - e^{-\alpha_s(\lambda)w}) (1 - R_f)$$

Quantum Efficiency,  $\eta$  of the photodetector

$$\eta \triangleq \frac{\# \text{ electron-hole pairs generated}}{\# \text{ incident photons}} = \frac{I_p/q}{P_0/hf}$$

$$\eta = (1 - e^{-\alpha_s(\lambda)w}) (1 - R_f)$$

→  $\eta$  varies in between 0.3 - 0.95

→ As  $w \uparrow$ ,  $\eta \uparrow$  ⇒ depletion layer should be thick so that most of the incident light is absorbed in this region

Responsivity,  $R$  of the photodetector

$R$  is defined as the photocurrent generated per unit optical power

$$R \triangleq \frac{I_p}{P_0} = \frac{q}{hf} \eta \leftarrow \text{quantum efficiency}$$

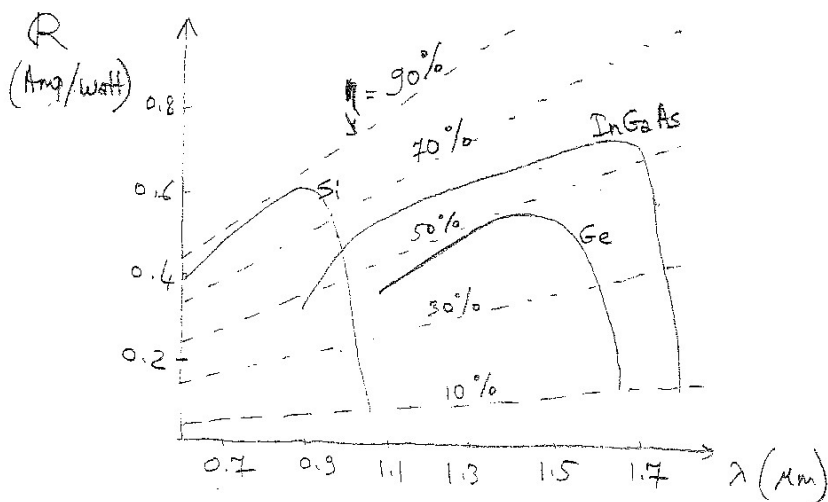

## → Avalanche Photodiodes (APD)

Has internal gain  $\Rightarrow$  increases the sensitivity since current is amplified before it goes to amplifier stage.  
 Structure (reach-through avalanche photodiode (RAPD))

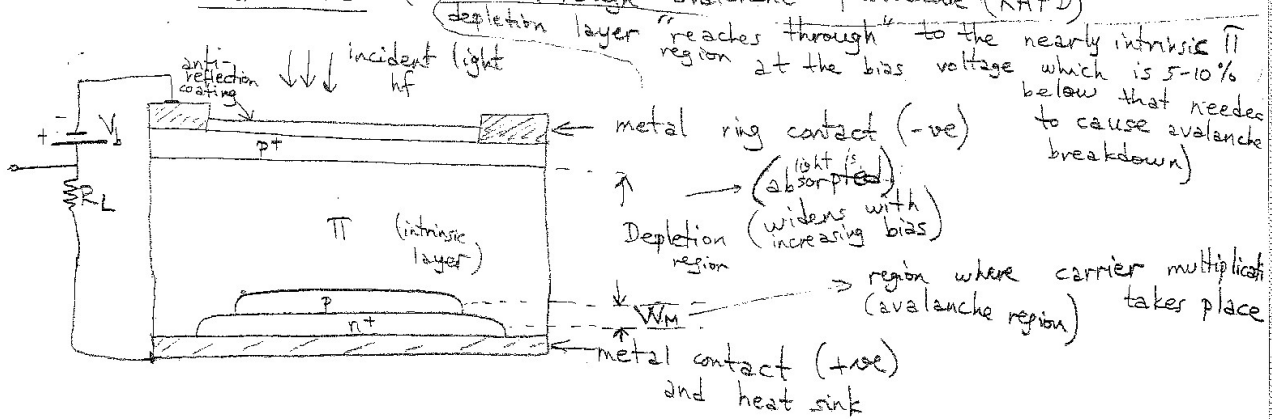

### Operation

- High reverse bias is applied.
  - Incoming photon generates electron-hole pairs
  - In the high field region, electrons or holes can gain enough energy to ionize bound electrons in the valence band. (when they collide the bound electrons) (Impact ionization)
  - High electric field causes the new carriers to accelerate, resulting in further impact ionization. (avalanche effect)
- $m =$  statistically varying current gain

$$\langle m \rangle = M = \text{average current gain of APD} = \frac{I_M}{I_p}$$

$I_M$  ← average of the multiplied output current  
 $I_p$  ← average of the unmultiplied (primary) output current

$$M = 80 - 150$$

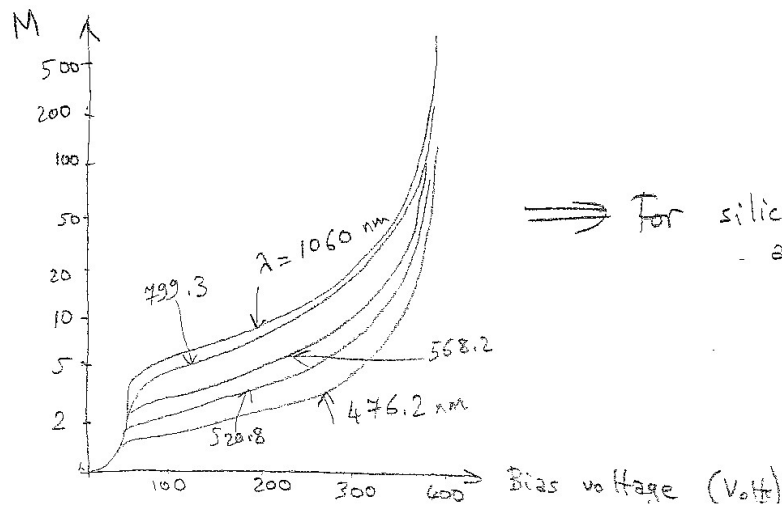

⇒ For silicon  $n^+ - p - \Pi - p^+$  avalanche photodiode

→ Responsivity for APD

$$R = R_{APD} M = \frac{nq}{hf} M$$

↑  
responsivity of unity current gain

→  $(SNR)_i = SNR$  at the input of the amplifier

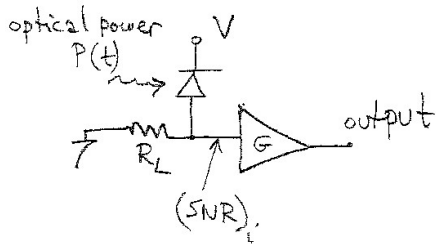

$$(SNR)_i = \frac{S_i}{N_i}$$

← signal power at the amplifier input  
 ← noise " " " " " "

$$N_i = N_{R_L} + N_D$$

↑ noise power due to  $R_L$       ↑ noise power due to the photodetector only

$$N_{R_L} = \langle i_r^2 \rangle = \text{thermal (Johnson) noise of the load resistor} = \frac{4kT(\Delta f)}{R_L}$$

here  $\langle \rangle =$  average value

Boltzmann's constant  
 ↓  
 $k$   
 absolute temperature  
 $T$   
 load resistance  
 $R_L$   
 bandwidth used

$$N_D = \langle i_Q^2 \rangle + \langle i_{DB}^2 \rangle + \langle i_{DS}^2 \rangle$$

↑ photo detector quantum or shot noise power      ↑ bulk dark current (noise power also = shot noise associated with dark current)      ↑ surface dark current noise power

Since uncorrelated

Detector noises

— Quantum noise (shot noise)  $\langle i_Q^2 \rangle$

Due to the random nature of the production and collection of photoelectrons (Poisson process). Since quantum noise is present with the presence of optical power, it determines the minimum detectable power if all other noise sources are optimized.

$$\langle i_Q^2 \rangle = 2q I_p (Af) M^2 F(M)$$

Here  $I_p$  is the average primary photocurrent  
 where  $i_{ph}(t) = I_p + i_p(t) \Rightarrow M i_{ph}(t) = M I_p + M i_p(t)$   
 (modulated) instantaneous primary photocurrent  $\rightarrow$  average photocurrent  $\rightarrow$  signal component (a.c.) of the photocurrent  $\rightarrow$  multiplied photocurrent  $\rightarrow$  signal component for avalanche photodiode  
 $i_{ph} = \frac{q}{hf} P(t)$  ← modulated optical power

$F(M)$  = excess noise factor due to the random nature of avalanche current gain

$$F \triangleq \frac{\langle m^2 \rangle}{\langle m \rangle^2} = M^2 \quad m = \text{random current gain}$$

$$F \cong M^x \Rightarrow \text{empirical}$$

where  $x = 0.5$  for silicon APD  
 $x = 0.85 - 1.0$  for Ge APD } empirical values

small because for silicon  $k = \frac{\beta}{\alpha} \ll 1$  (see p. 51)  $\left\{ \begin{array}{l} \text{hole ionization rate} \\ \text{electron ionization rate} \end{array} \right.$   
 low noise so Si APD are popular

For pin photodiodes  $F = M = 1$

— Dark current noise = bulk dark current noise + surface dark current noise (leakage current)

Dark current is the current that flows through the bias circuit in the absence of incident light on the photodiode

Bulk dark current noise power =  $\langle i_{DB}^2 \rangle$   
 results from the thermally generated electrons and holes at the pn junction

$$\langle i_{DB}^2 \rangle = 2q I_D (Af) M^2 F(M)$$

↑  
 unmultiplied bulk dark current (in the order of nanoamperes)

Surface dark current noise power =  $\langle i_{DS}^2 \rangle$   
 results from the surface defects, cleanliness, bias voltage, surface area. (guard ring structure is used to prevent 'ds. Ring' shunt the leakage current away from the load resistor.)

$$\langle i_{DS}^2 \rangle = 2q I_L (\Delta f)$$

$\uparrow$  not effected by avalanche gain       $\uparrow$  surface leakage current

$\therefore N_D = \text{total detector noise power} = \langle i_Q^2 \rangle + \langle i_{DB}^2 \rangle + \langle i_{DS}^2 \rangle$

$$N_D = 2q (I_p + I_D) (\Delta f) M^2 F(M) + 2q I_L (\Delta f)$$

$$N_i = N_{R_L} + N_D = \frac{4kT(\Delta f)}{R_L} + N_D$$

$$S_i = \langle [M i_p(t)]^2 \rangle = M^2 \langle i_p^2 \rangle$$

$$\therefore (SNR)_i = \frac{M^2 \langle i_p^2 \rangle}{\underbrace{2q (I_p + I_D) M^2 (\Delta f) F(M) + 2q I_L (\Delta f)}_{\text{Detector noise powers}} + \underbrace{\frac{4kT(\Delta f)}{R_L}}_{\text{thermal noise pow of the load resistance}}}$$

→ Generally

- For pin photodiodes  $N_{R_L}$  dominates  $N_D \Rightarrow$   
 Thus " " make the system thermal noise limited.

- For APD,  $N_D$  dominates  $N_{R_L} \Rightarrow$   
 Thus APD makes the system quantum noise limited.

→ As  $M \uparrow$ ,  $S_i \uparrow$  and also  $N_D \uparrow$

For smaller values of  $M$  (but still  $M > 1$ )  
 $(SNR)_i \uparrow$  as  $M \uparrow$ , i.e. it is better to use APD instead of pin photodetector.  
 However for larger values of  $M$ ,  $F(M)$  becomes very large causing  $(SNR)_i$  to decrease. In this

case it is not advantageous to use APD.

Conclusion is there is an optimum value of  $M$  (current gain) in determining whether APD or pin photodiode is better in terms of noise performance. This optimum  $M$  depends <sup>not only</sup> on the detector parameters ( $I_L, \alpha, I_D$ ) but

also on external parameters ( $T, R_L, I_p$ ).  $F(M) = M^x$  i.e. you cannot design an optimum  $M$  detector but you can pick an optimum  $M$  detector.

→ Noise equivalent power = NEP  $\triangleq$  optical power (of specified  $\lambda$ ) required to produce a detector current equal to r.m.s noise current.  
i.e., NEP = optical power required to make SNR = 1.

Neglecting thermal noise and surface dark current noise

$$(SNR)_i = 1 = \frac{M^2 \langle i_p^2 \rangle}{2q(I_p + I_D) M^2 (AF) F(M)}$$

Assume there is no modulation and the signal power = carrier power

⇒  $\langle i_p^2 \rangle$  = electric signal power required to make  $(CNR)_i = 1$  is found as

$$M^2 \langle i_p^2 \rangle = 2q(I_p + I_D) M^2 F(M) (AF)$$

Carrier-to-noise ratio

$$M^2 \langle i_p^2 \rangle = M^2 \left( \frac{q}{hf} \right)^2 \langle P^2 \rangle \quad \text{since } i_p = \frac{q}{hf} P$$

$$\therefore M^2 \left( \frac{q}{hf} \right)^2 \langle P^2 \rangle = 2q(I_p + I_D) M^2 F(M) (AF)$$

$$\langle P^2 \rangle = \frac{2q(I_p + I_D) M^2 F(M) (AF)}{M^2 \left( \frac{q}{hf} \right)^2}$$

∴ optical power to make  $(CNR)_i = 1$  is

$$\sqrt{\langle P^2 \rangle} = \frac{\sqrt{2q(I_p + I_D) M^2 F(M) (AF)}}{M \left( \frac{q}{hf} \right)}$$

$$NEP = \frac{\sqrt{\langle P^2 \rangle}}{\sqrt{AF}} = \frac{\sqrt{2q(I_p + I_D) M^2 F(M)}}{R \leftarrow \text{responsivity}} \quad \left( \frac{\text{watts}}{\sqrt{\text{Hz}}} \right)$$

→ Detectivity =  $D = \frac{1}{NEP} \left( \frac{\text{Hz}^{1/2}}{\text{watt}} \right)$

→ Specific Detectivity =  $D^* \triangleq$  detectivity adjusted to be independent of the detector area and bandwidth

$D^* = D A^{1/2} \left( \frac{\text{cm-Hz}^{1/2}}{\text{watt}} \right)$   
↑ detector area

Detector bandwidth (speed)

Depends on:

— The RC time constant of the photodiode and the amplifier.

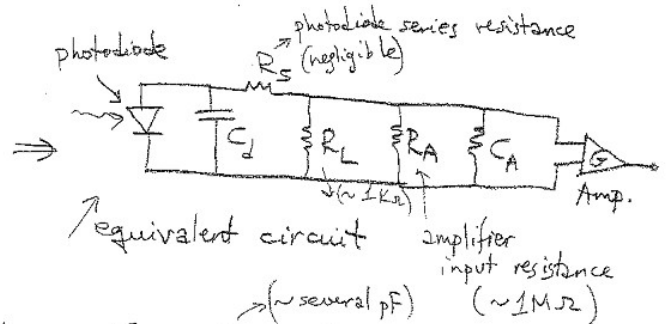
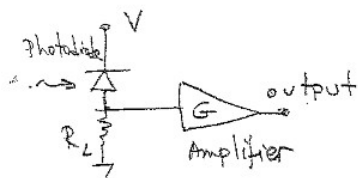

$B = \frac{1}{2\pi C_T R_T}$

where  $C_T = C_d + C_A$   
(~ several pF)      (~ 1MΩ)  
↑ junction cap.      ↑ amplifier capacitance ~ several pF  
↑ packaging cap.  
 $C_j = \frac{\epsilon A}{w}$   
↑ permittivity of the semiconductor material      ↑ diffusion layer area      ↑ depletion layer width

$R_T = R_L // R_A$  since  $R_s$  negligible

— Photocarrier transit time ( $t_d$ ) in traversing the depletion region.

$t_d = \frac{w}{v_d}$  ← depletion layer width } As  $w \uparrow, t_d \uparrow$  i.e. B.W. due to transit time ↓  
↑ drift velocity at  $2 \times 10^6 \text{ V/cm}$  field strength

For Si:  $v_{d, \text{max}} = \begin{cases} 8.4 \times 10^6 \text{ cm/s} & \text{for electrons} \\ 4.6 \times 10^6 \text{ cm/s} & \text{for holes} \end{cases} \Rightarrow$  high speed Si photodiode with  $w = 10 \mu\text{m} \Rightarrow t_d = 0.1 \text{ ns}$

— Diffusion time of photocarriers generated outside the depletion region.

— Diffusion process is slow compared to drift in the depletion region

— To have small diffusion time, the photocarriers should be generated in the depletion region or very close to the depletion region. One way of achieving this is to have  $w$  large (will also increase  $I_p$ )

From  $I_p = \frac{q}{hf} P_0 (1 - e^{-\alpha_s w}) (1 - R_f)$  expression

one must pick  $\alpha_s w \gg 1 \Rightarrow w \gg \frac{1}{\alpha_s}$

→ If  $w \gg \frac{1}{\alpha_s}$  and  $C_j = \frac{\epsilon A}{w}$  is small  $\Rightarrow$  high bandwidth  
↑ junction capacitance

→ If  $w \gg \frac{1}{\alpha_s}$  but  $C_j$  large then bandwidth is determined by  $\frac{1}{2\pi R_L C_d}$  → detector cap.

→ As  $w \downarrow$   $C_j \uparrow \Rightarrow$  causing bandwidth  $\downarrow$   
 → Also as  $w \downarrow$   $t_d \downarrow \Rightarrow$  " " " "  $\uparrow$  } There is a compromise

→ Also as  $w \downarrow$  less absorption will take place in the depletion region causing quantum efficiency  $\downarrow$  } sec comp.

→ Schottky photodiodes  $\sim 100$  GHz is achieved (but low efficiency)

Temperature effect on avalanche gain

For constant bias voltage as  $T \uparrow$   $M \downarrow$ .

A compensation circuit is needed in the receiver to adjust the bias voltage applied on the photodetector as  $T$  changes in order to keep  $M$  constant.

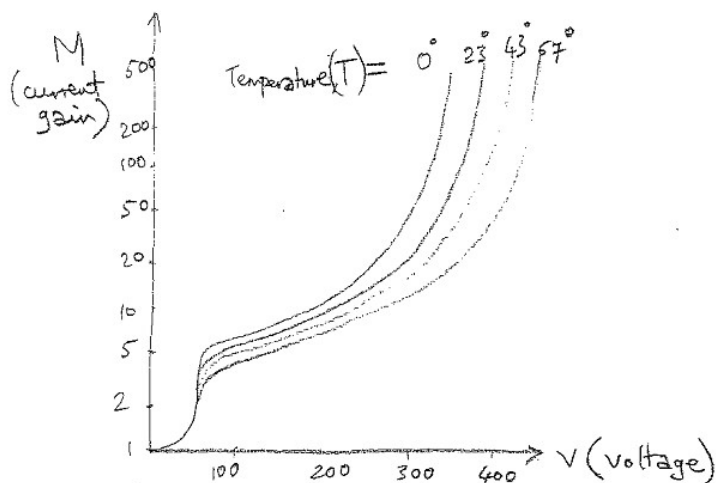

## Photodiode materials

- In 0.8 - 0.9  $\mu\text{m}$  range Si is used most because avalanche multiplication noise  $[F(M)]$  is small  $\Rightarrow$  high receiver sensitivity and also Si technology is highly developed. Also Ge, GaAs, InGaAs, InGaAsP is being used in 0.8 - 0.9  $\mu\text{m}$  range.
- In 1.0 - 1.55  $\mu\text{m}$  range Ge is used most since responsivity of Ge in this range is better than Silicon. However Ge has high avalanche multiplication noise, higher dark current. Also InGaAsP, GaAsSb, InGaAs, GaSb is being used in 1.0 - 1.6  $\mu\text{m}$  range.

## Comparison of pin (Si and Ge) and APD (Si and Ge) performance

	Pin		APD	
	Silicon	Germanium	Si	Ge
$\lambda$ range ( $\mu\text{m}$ )	0.4 - 1.1	0.5 - 1.8	0.4 - 1.1	0.5 - 1.65
$\eta$ = quantum efficiency (%)	80	50	80	70
rise time (ns)	0.01	0.3	0.5	0.25
reverse bias voltage (V)	15	6	170	40
Responsivity (A/W)	0.5	0.7	0.7	0.6
M (current gain)	1.0	1.0	80 - 150	80 - 150
Sensitivity	-35 $\text{dB}_m$ (depends on BER)		-50 $\text{dB}_m$ (depends on BER)	
dark current	$< 10^{-9}$ A		$10^{-10} - 10^{-11}$ A	
cost	cheaper		expensive	

## 8. Optical Fiber Transmitter

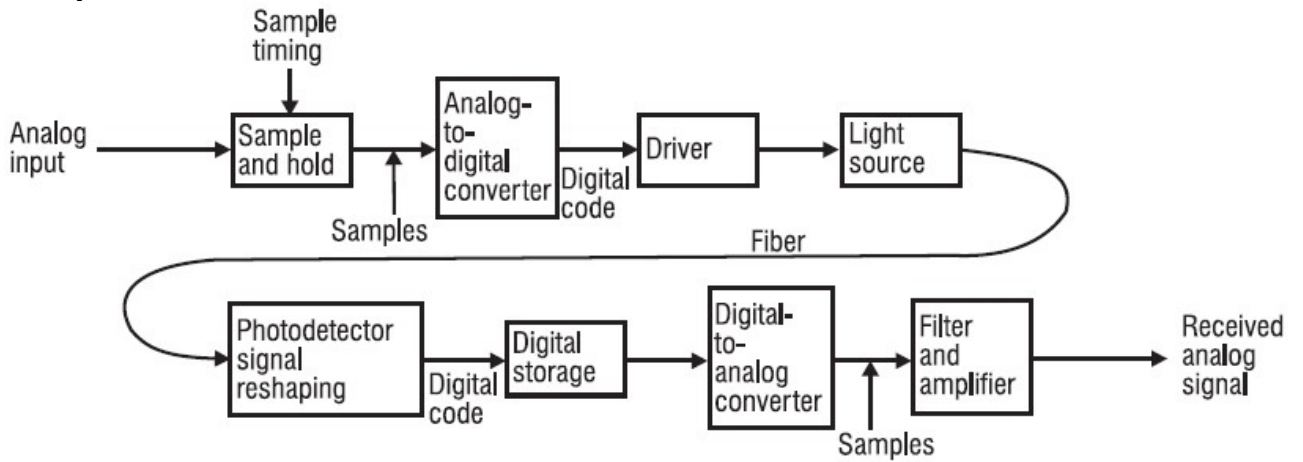

### PULSE CODE MODULATION (PCM)

PCM is the conversion of an analog signal into a  $2n$ -digit binary code.

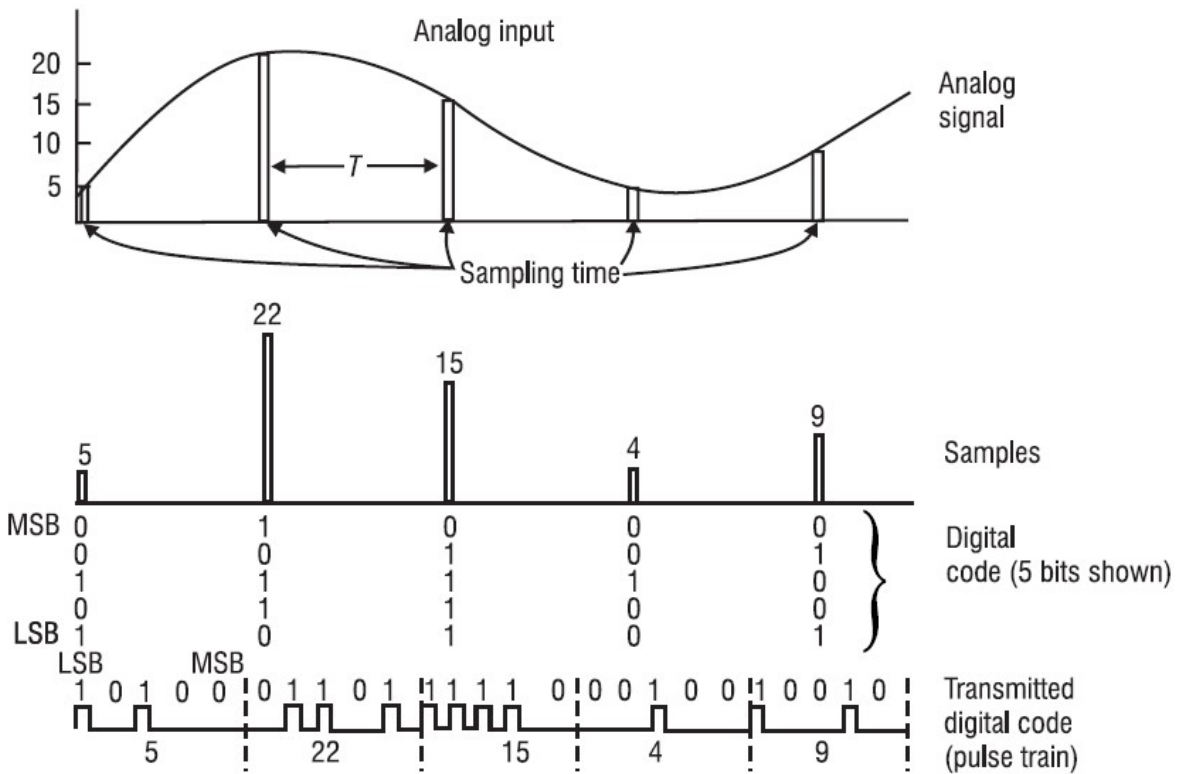

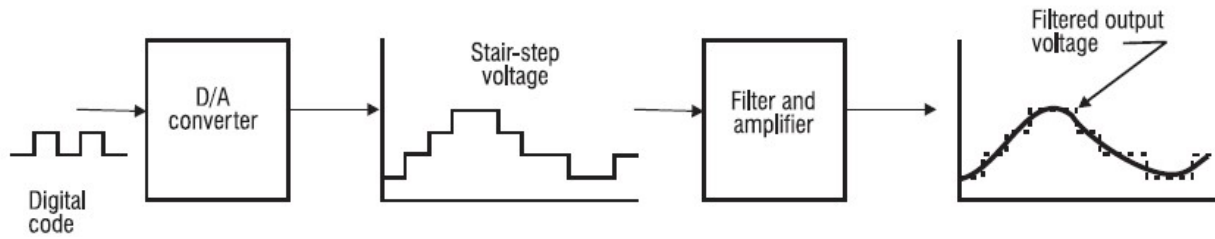

An analog signal is placed on the input of a sample and hold.

The sample and hold circuit is used to “capture” the analog voltage long enough for the conversion to take place.

The output of the sample and hold circuit is fed into the analog-to-digital converter (A/D).

An A/D converter operates by taking periodic discrete samples of an analog signal at a specific point in time and converting it to a  $2^n$ -bit binary number.

For example, an 8-bit A/D converts an analog voltage into a binary number with  $2^8$  discrete levels (between 0 and 255).

For an analog voltage to be successfully converted, it must be sampled at a rate at least twice its maximum frequency. This is known as the Nyquist sampling rate.

An example of this is the process that takes place in the telephone system. A standard telephone has a bandwidth of 4 kHz. When you speak into the telephone, your 4-kHz bandwidth voice signal is sampled at twice the 4-kHz frequency or 8 kHz. Each sample is then converted to an 8-bit binary number. This occurs 8000 times per second. Thus, if we multiply  $8 \text{ k samples/s} \times 8 \text{ bits/sample} = 64 \text{ kbits/s}$ , we get the standard bit rate for a single voice channel which is 64 kbits/s.

The output of the A/D converter is then fed into a driver circuit that contains the appropriate circuitry to turn the light source on and off.

The process of turning the light source on and off is known as modulation.

The light then travels through the fiber and is received by a photodetector that converts the optical signal into an electrical current.

A typical photodetector generates a current that is in the micro- or nanoamp range, so amplification and/or signal reshaping is often required.

Once the digital signal has been reconstructed, it is converted back into an analog signal using a device called a digital-to-analog converter or DAC.

A digital storage device or buffer may be used to temporarily store the digital codes during the conversion process.

The DAC accepts an  $n$ -bit digital number and outputs a continuous series of discrete voltage “steps.”

All that is needed to smooth the stair-step voltage out is a simple low-pass filter with its cutoff frequency set at the maximum signal frequency.

## DIGITAL ENCODING SCHEMES

Signal format is an important consideration in evaluating the performance of a fiber optic system..

The signal format directly affects the detection of the transmitted signals.

The accuracy of the reproduced signal depends on the intensity of the received signal, the speed and linearity of the receiver, and the noise levels of the transmitted and received signal.

Many coding schemes are used in digital communication systems, each with its own benefits and drawbacks.

The most common encoding schemes are the return-to-zero (RZ) and non-return-to-zero (NRZ).

The NRZ encoding scheme, for example, requires only one transition per symbol, whereas RZ format requires two transitions for each data bit.

This implies that the required bandwidth for RZ must be twice that of NRZ. This is not to say that one is better than the other.

Depending on the application, any of the code formats may be more appropriate than the others.

For example, in synchronous transmission systems in which large amounts of data are to be sent, clock synchronization between the transmitter and receiver must be ensured. In this case Manchester encoding is used.

The transmitter clock is embedded in the data. The receiver clock is derived from the guaranteed transition in the middle of each bit.

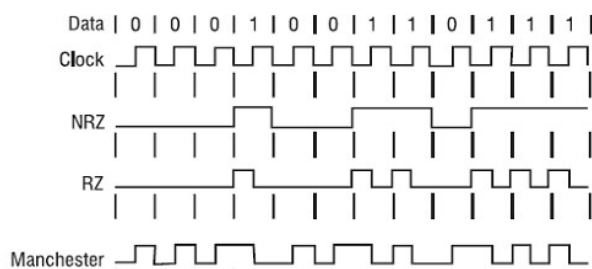

Format	Symbols per Bit	Self-Clocking	Duty Factor Range (%)
NRZ	1	No	0-100
RZ	2	No	0-50
Manchester (Biphase L)	2	Yes	50

Digital systems are analyzed on the basis of rise time rather than on bandwidth.

The rise time of a signal is defined as the time required for the signal to change from 10% to 90% of its maximum value.

The system rise time is determined by the data rate and code format.

Depending on which code format is used, the number of transitions required to represent the transmitted data may limit the overall data rate of the system.

The system rise time depends on the combined rise time characteristics of the individual system components.

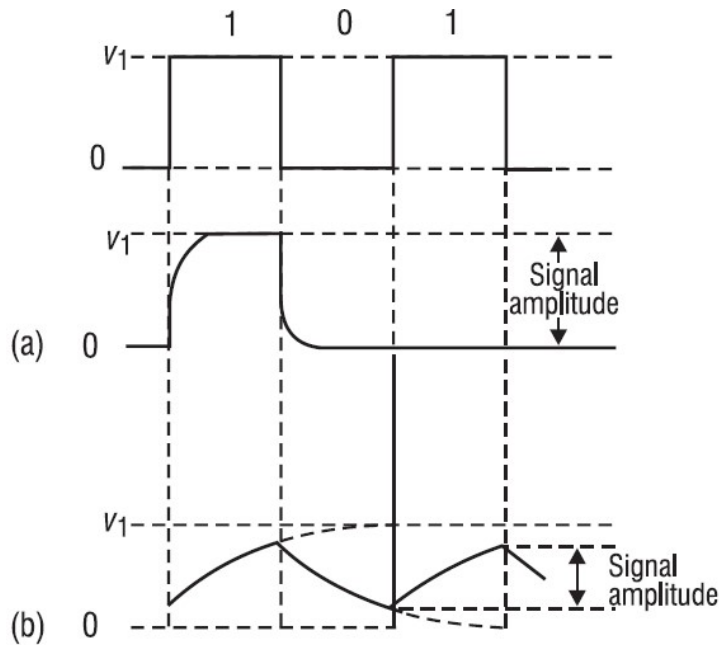

*Effect of rise time: (a) Short rise time (b) Long rise time*

(a) represents a signal with adequate rise time. Even though the pulses are somewhat rounded on the edges, the signal is still detectable.

In (b) however, the transmitted signal takes too long to respond to the input signal.

The effect is the below figure where at high data rates, the rise time limitations cause the data to be distorted and thus lost.

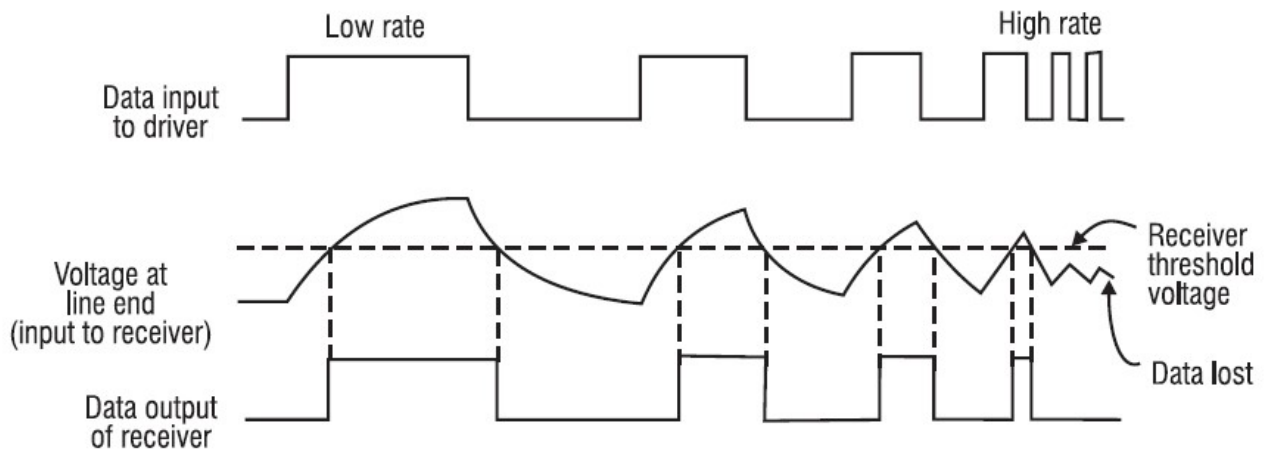

Source: *The TTL Application Handbook*, August 1973f, p. 14-7.  
 Reprinted with permission of National Semiconductor.

*Distortion of data bits by varying data rates*

To avoid this distortion, an acceptable criterion is to require that a system have a rise time  $t_s$  of no more than 70% of the pulse width  $T_p$ ,  $t_s \leq 0.7 T_p$

For an RZ,  $T_p$  takes half the bit time  $T$  so that  $t_s \leq 0.7 T/2$  or  $t_s \leq 0.35/B_r$  where  $B_r = 1/T$  is the system bit rate.

For an NRZ format,  $T_p = T$  and thus  $t_s \leq 0.7/B_r$

RZ transmission requires a larger-bandwidth system.

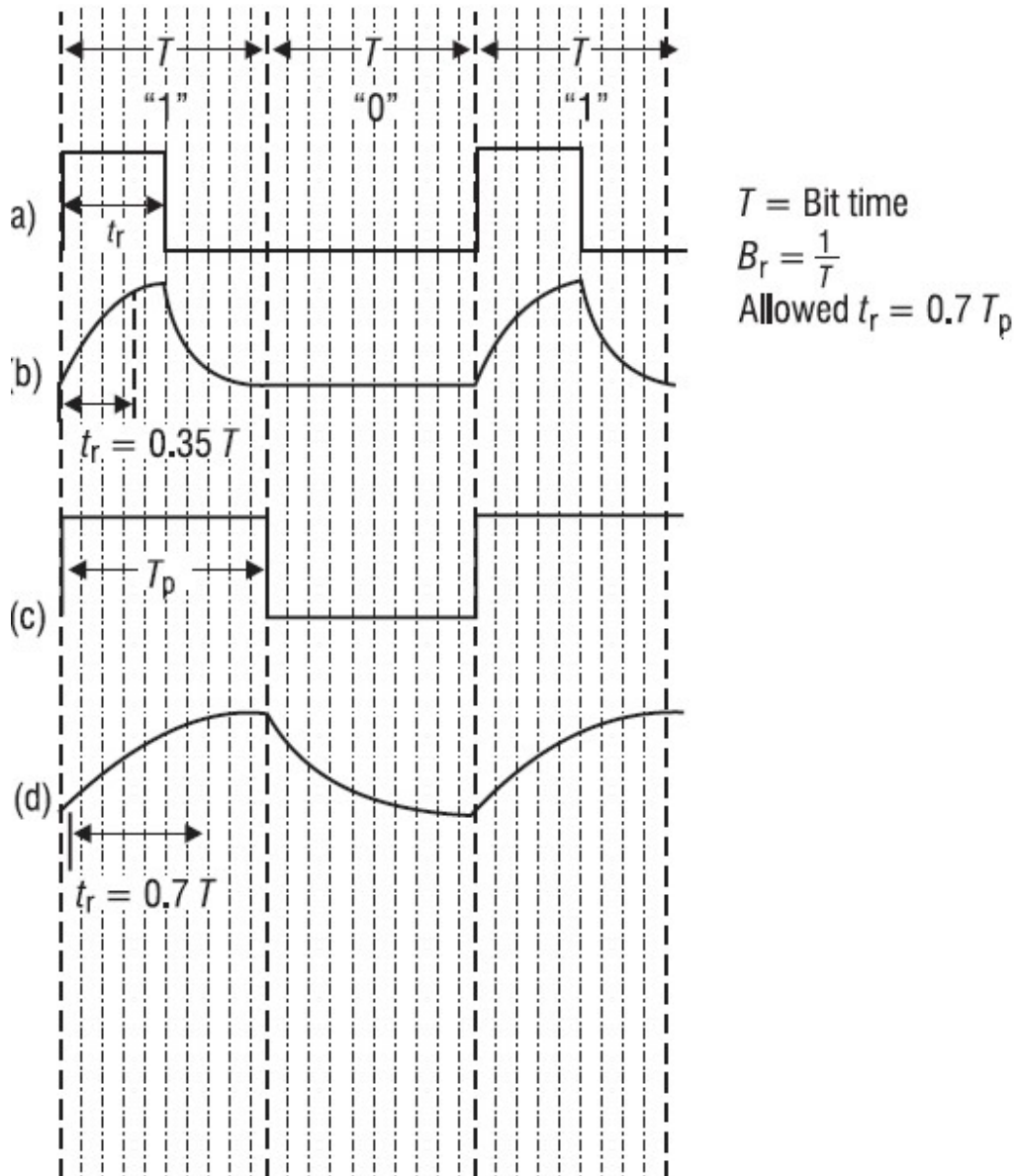

*Effects of system rise time for RZ format and NRZ format:*

- a) Transmitted RZ pulse train
- b) Received RZ signal with allowable  $t_r$
- c) Transmitted NRZ pulse train
- d) Received NRZ pulse train with allowable  $t_r$

## 9. Optical Receiver Systems

## Noise Limitation

Draw fig. 4.30 of G. Keiser book

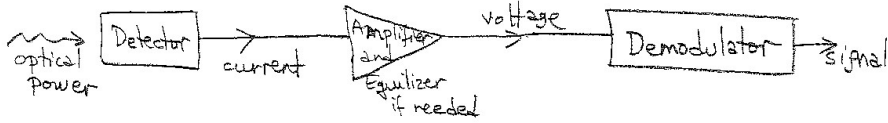

includes the choice of PIN or APD.

- Minimum SNR is preset for an acceptable system performance.
- Minimum average detector current is determined to satisfy the SNR requirement.
- Minimum detectable optical power is found.

Types of modulation in fiber communication:

Analog modulation

- Direct modulation of optical carrier power by baseband signal.
- Modulation of the optical carrier power by a frequency modulated subcarrier.

Digital modulation

- PCM of optical carrier power

## Sources of receiver noise

- All the photodetector noises discussed before (quantum, dark)
- Thermal noise (thermal motion of charge carriers) due to the amplifier input resistance, the bias (load) resistance, and the photodetector resistance
- Active electronic device such as a transistor. The magnitude of this noise depends on the material and design of the device and its bias. (Si, Ge etc)  
(FET, MESFET, or BJT)

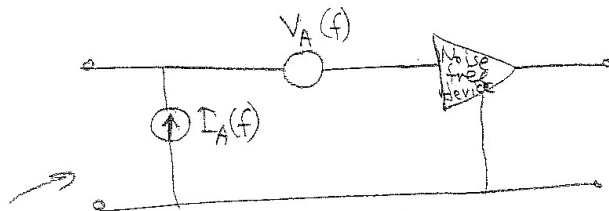

Equivalent noise circuit of an active electronic device where  $V_A$  is the voltage source representing the rms noise voltage per unit bandwidth and  $I_A$  is the current source representing the rms noise current per unit bandwidth.

# Signal-to-noise ratio for the voltage amplifier circuit

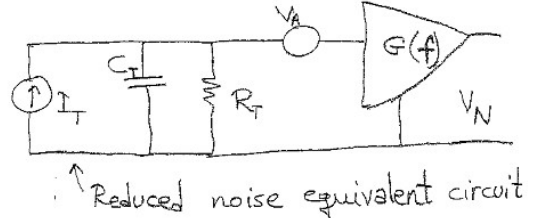
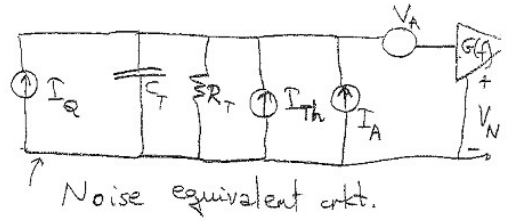
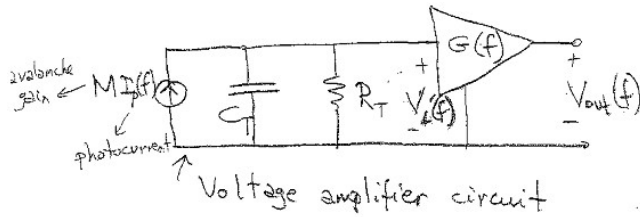

where  $C_T = \text{total input capacitance} = C_d + C_A$

$I_A = \text{rms noise current of the amplifier per unit bandwidth} \approx \begin{cases} 10^{-14} \text{ A}/\sqrt{\text{Hz}} & \text{for Si-FET} \\ 2 \times 10^{-12} \text{ A}/\sqrt{\text{Hz}} & \text{for Si-BJT} \\ 10^{-13} \text{ A}/\sqrt{\text{Hz}} & \text{for GaAs MESFET} \end{cases}$

$R_T = R_L // R_A // R_D$

$V_A = \text{rms noise voltage of the amplifier per unit BW} \approx \begin{cases} 4 \text{ nV}/\sqrt{\text{Hz}} & \text{for Si-FET} \\ 2 \text{ nV}/\sqrt{\text{Hz}} & \text{for Si-BJT} \\ 1 \text{ nV}/\sqrt{\text{Hz}} & \text{for GaAs MESFET} \end{cases}$

$I_T^2 = I_q^2 + I_{Th}^2 + I_A^2$

noise power due to total noise current  
 noise power due to quantum noise current  
 noise power due to thermal noise current

$I_q = \text{multiplied quantum noise in the photodiode}$   
 $I_{Th} = \text{thermal noise current}$

Dark noise is neglected.

$\text{Voltage SNR} = K = \frac{V_{out}}{V_N}$

output SNR      output signal voltage      output noise voltage

$\text{Output signal voltage} = V_{out}(f) = G(f) V_i(f) = G(f) \frac{R_T M I_p(f)}{(1 + j2\pi f C_T R_T)}$

Frequency band of the overall crkt. that the input signal/photocurrent

sees is  $\frac{1}{2\pi R_T C_T}$ , i.e., the input frequencies above  $\frac{1}{2\pi R_T C_T}$  are

bandlimited at the output. In order for all input frequencies (within the signal bandwidth  $\Delta f$ ) to see the same gain, an equalizer is needed, i.e.

$$G(f) = G_0 (1 + j 2\pi f C_T R_T)$$

so that

$$V_{out} = G_0 M R I_p$$

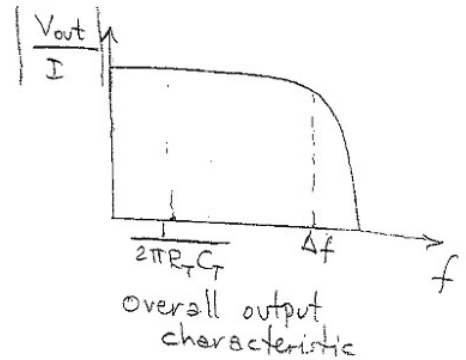
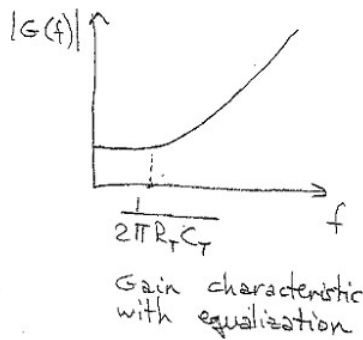
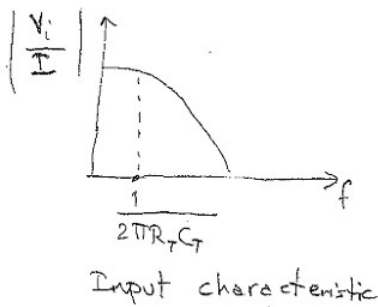

→ Total rms output noise power  $= V_N^2 = \int_{\Delta f} |G(f)|^2 V_A^2 df + \int_{\Delta f} \frac{|G(f)|^2 R_T^2 I_T^2 df}{|1 + j 2\pi R_T C_T f|^2}$  ← since  $V_A$  and  $I_T$  are per unit bandwidth

For  $G(f) = G_0 (1 + j 2\pi f C_T R_T)$

$$V_N^2 = G_0^2 \int_0^{\Delta f} \{ (1 + 4\pi^2 f^2 C_T^2 R_T^2) V_A^2 + R_T^2 I_T^2 \} df$$

Assuming  $V_A$  and  $I_T$  are independent of frequency in  $\Delta f$   
 $(\Rightarrow I_p(f) = I_p)$

$$V_N = G_0 \left\{ \left( 1 + \frac{4}{3} \pi^2 (\Delta f)^2 C_T^2 R_T^2 \right) V_A^2 + R_T^2 I_T^2 \right\}^{1/2} (\Delta f)^{1/2}$$

→ ∴  $K = \frac{V_{out}}{V_N} = \frac{I_p}{\left\{ \frac{V_A^2}{M^2} \left( \frac{1}{R_T^2} + \frac{4\pi^2}{3} (\Delta f)^2 C_T^2 \right) + 2g I_p F(M) + \frac{4kT}{M^2 R_T} + \frac{I_A^2}{M^2} (\Delta f)^2 \right\}^{1/2}}$

Here  $\Delta f$  is the modulation bandwidth. In direct modulation  $\Delta f$  is the baseband frequencies, in FM subcarrier systems  $\Delta f$  extends over

the range of frequency modulation. In PCM,  $\Delta f = (\text{Bit rate})/2$ .

→ K determines the quality of the communication channel and in system design minimum K is always specified.

$$K > 12 \Rightarrow \text{SNR} > 20 \log K \text{ dB for PCM}$$

$$K > 200 \Rightarrow \text{SNR} > 46 \text{ dB for analogue channel.}$$

→ Features of K in guiding the general design of the system and evaluating its expected performance:

— Initially, as  $M \uparrow$   $K \uparrow$  until the quantum (shot) noise term (c) dominates other terms. Thus, there is an optimum  $M = M_{\text{opt}}$  above which  $K \downarrow$  (ie it is not always advantageous to use APD)

— If terms (a) and (d) are significant,  $\uparrow$  in  $R_T \Rightarrow \uparrow$  in K. However high  $R_T$  brings some problems like the need for equalization and the reduction in the dynamic range of the amplifier.

— If  $\Delta f$  is large term (b) dominates. Thus  $C_T$  should be minimized:  $\downarrow$  in  $C_T \xrightarrow{\text{also}} \downarrow$  in the equalization amount needed.

— Term (c) (quantum noise) causes the total noise to be dependent on the level of the received signal. This is a distinguished feature of optical communication systems as compared to other types of " " " "

— Even though quantum noise is Poisson distributed, in obtaining K, it is assumed that all noise sources are uncorrelated Gaussian.

→ The Ideal Case (ie quantum noise (shot noise) limited system)

M sufficiently large so that term (c) dominates.

$$\Rightarrow K = \frac{I_p}{(2q I_p F(M) \Delta f)^{1/2}} \Rightarrow I_p > 2q F(M) K^2 \Delta f$$

↑ quantum limit to detector sensitivity

since  $P_r = \frac{I_p}{R_{\text{APD}}} \xrightarrow{\text{responsivity}} P_r > \frac{2e F(M) K^2 \Delta f}{R_{\text{APD}}}$

average received optical power corresponds to  $P_0$  in detector section      ↓ minimum rec. power for quantum limited operation

→ High Input Resistance Amplifier (Integrating Amplifier)

If terms (a) and (d) in the SNR expression are dominating over others (i.e. the thermal noise and amplifier noise voltage are high) then if  $R_T \uparrow$  the receiver can be made shot noise limited. But increasing  $R_T$  causes integration of the signal (i.e. rec. bandwidth =  $\frac{1}{2\pi R_T C_T}$ ) so equalization becomes necessary. Also for  $R_T$  large dynamic range will be decreased.  
If  $R_T$  is large

$$K = \frac{I_p}{\left\{ \frac{V_A^2}{M^2} \frac{4\pi^2}{3} (\Delta f)^2 C_T^2 + 2gI_p F(M) + \frac{I_A^2}{M^2} \right\}^{1/2} (\Delta f)^{1/2}}$$

(b) (c) (e)

Define  $(\Delta f)_0 \triangleq \frac{\sqrt{3} I_A}{2\pi C_T V_A}$

⇒ Signal bandwidth  $(\Delta f)$  needed for quantum noise limited operation (ideal case) (i.e. conditions for term (c) dominating other terms)

→ If  $\Delta f < (\Delta f)_0$  <sup>①</sup> term (e) > term (b) so term (e) dominates when  $2gI_p F(M) > \frac{I_A^2}{M^2}$  ②

At quantum noise limited operation  $I_p = 2g F(M) K^2 \Delta f$   
found before ③

Subst. ③ into ②

$$(2g F(M) K)^2 \Delta f > \frac{I_A^2}{M^2} \Rightarrow \Delta f > \frac{I_A^2}{(2g F(M) K M)^2} = (\Delta f)_0 \quad \text{④}$$

→ If  $\Delta f > (\Delta f)_0$  <sup>⑤</sup> term (b) dominates term (e) so term (c) dominates when  $2gI_p F(M) > \frac{V_A^2}{M^2} \frac{4\pi^2}{3} (\Delta f)^2 C_T^2$  ⑥

At quantum limited operation  $I_p$  is given by ③  
Subst. ③ into ⑥ we have



$$\Delta f < \frac{3(qMF(M)K)^2}{(\pi C_V A)^2} = (\Delta f)_2 \quad \text{--- (7)}$$

→ So if  $(\Delta f)_1 < \Delta f < (\Delta f)_2$  then we have quantum limited operation.  
 $\swarrow$   $\uparrow$   
 Eq. (4) Eq. (7)

With APD, both Si-FET and Si-BJT permit quantum noise limited operation over most practical frequencies.

### Low Input Resistance Amplifier

If  $\frac{1}{2\pi RC} > \Delta f \Rightarrow R < \frac{1}{2\pi C \Delta f}$ , then no equalization is needed. If  $R < \frac{1}{2\pi C \Delta f}$ , then from SNR expression, it can be found that if

$$\frac{V_A^2}{4kT} < R < \frac{4kT}{I_A^2} \quad \text{--- (8)}$$

then thermal noise (term d) exceeds amplifier noise (term a and b). In addition to (8) if quantum noise (term c) exceeds thermal noise (term d), i.e.

$$2qI_p F(M) > \frac{4kT}{M^2 R} = \frac{8\pi kT C \Delta f}{M^2} \quad \text{--- (9)}$$

then the operation will be quantum limited (best among those could be achieved)

Minimum quantum noise limited current is given by (3)

Using (3) in (9) we have

$$C_T < \frac{(qMF(M)K)^2}{2\pi kT}$$

→ A good APD ensures quantum noise limited operation even with a low resistance and no equalization voltage amplifier.

## The Transimpedance Feedback Amplifier

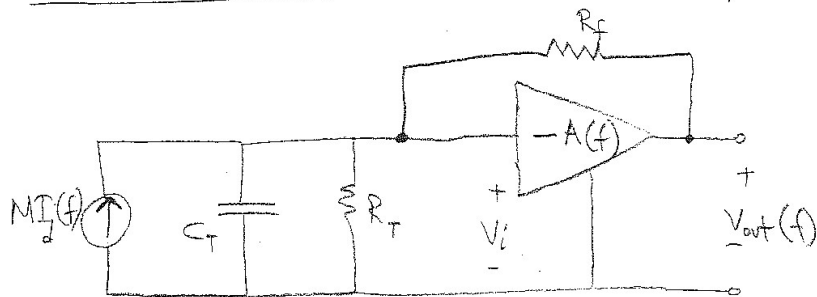

- Most usually preferred because
  - Need for equalization can be avoided
  - At the same time the amplifier noise may be much less as compared to the noise in an unequalized voltage amplifier.
- The SNR for feedback amplifier is identical to K expression found for voltage amplifier except that  $\frac{1}{R_T}$  is replaced by  $\frac{1}{R_T} + \frac{1}{R_f}$ .
- Thus if  $R_f$  is small enough ( $R_f \sim 10 \text{ k}\Omega$  where  $R_T \sim 40 \text{ k}\Omega$ ) than one can pick  $R_T$  small enough without increasing the amplifier voltage noise <sup>(term a)</sup> and the thermal noise (term d) and also without using an equalizer (since  $R_T$  is small)
- Main problem in transimpedance amplifier is the amplifier stability. Use of a long feedback path around a high gain, high input impedance amplifier causes high frequency oscillation as a result of positive feedback via parasitic capacitance. To avoid oscillations careful layout and effective screening of sensitive components are needed.

### 10. Introduction to Free Space Optics (FSO) Systems

Based on their transmission range, WOC (Wireless Optical Communication) can be classified into five broad categories:

- (i) Ultrashort-range WOC – used in chip-to-chip communication or all optical lab-on-a-chip system.

- (ii) Short-range WOC – used in wireless body area networks (WBANs) or wireless personal area networks (WPANs).
- (iii) Medium-range WOC – used in indoor IR or visible light communication (VLC) for wireless local area networks (WLANs) and inter-vehicular and vehicle-to-infrastructure communications.
- (iv) Long-range WOC – used in terrestrial communication between two buildings or metro area extensions.
- (v) Ultra-long-range WOC – used in ground-to-satellite/satellite-to-ground or inter-satellite link or deep space missions.

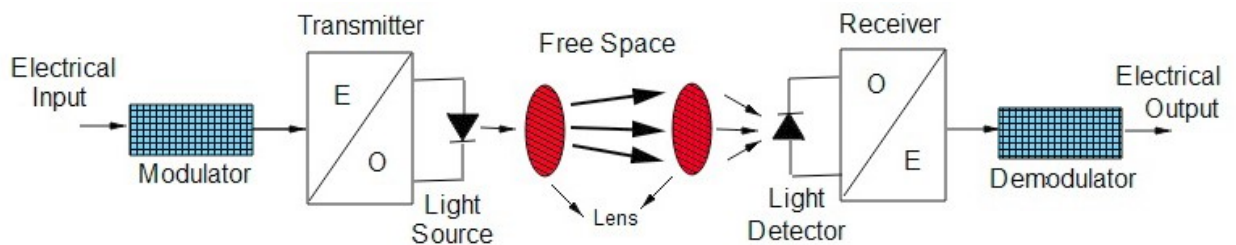
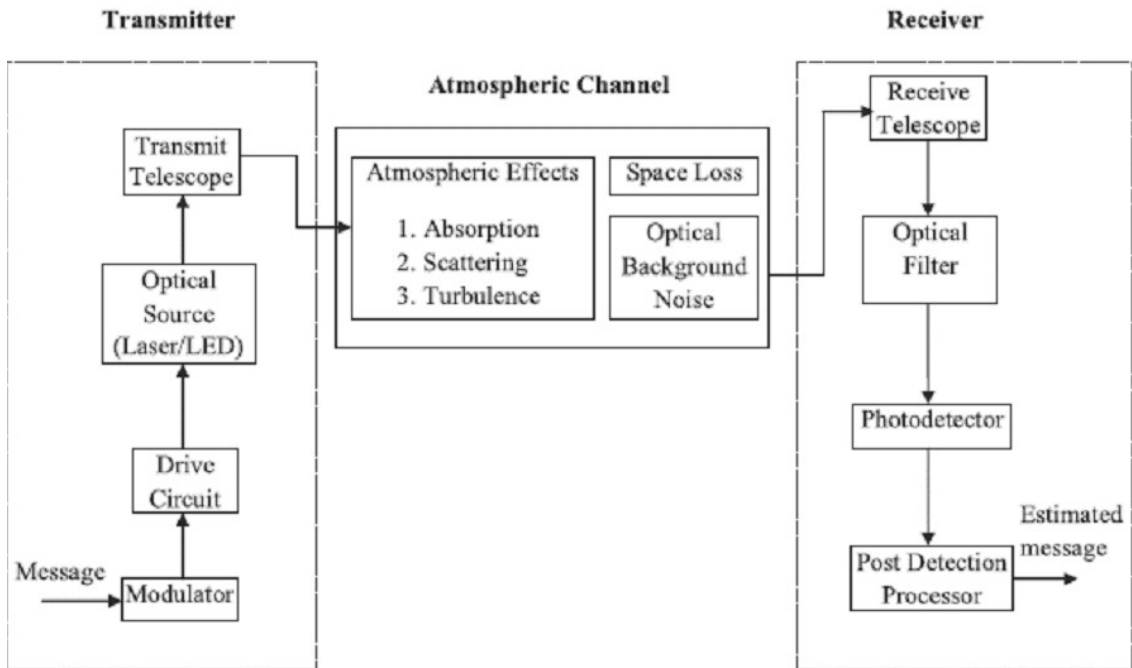

Block diagram of WOC



FSO applications:

- Telecommunication and computer networking

- Point-to-point LOS links
- Temporary network installation for events or other purpose as disaster recovery
- For communications between spacecraft, including elements of satellite constellation
- Security applications
- Military application: (its potential for low electromagnetic emanation when transferring sensitive data for air forces)
- Metro network extensions: carriers can deploy FSO to extend existing metropolitan area fiber rings, to connect new networks, and, in their core infrastructure, to complete SONET rings.
- Enterprise connectivity: the ease with which FSO links can be installed makes them a natural for interconnecting local area network segments that are housed in buildings separated by public streets or other right-of-way property.
- Fiber backup: FSO may also be deployed in redundant links to backup fiber in place of a second fiber link.
- Backhaul: FSO can be used to carry cellular telephone traffic from antenna towers back to facilities wired into the public switched telephone network.
- Service acceleration: FSO can be also used to provide instant service to fiber-optic customers while their fiber infrastructure is being laid.
- Last-Mile access: In today's cities, more than 95% of the buildings do not have access to the fiber optic infrastructure due to the development of communication systems after the metropolitan areas. FSO technology seems a promising solution to the connection of endusers to the service providers or to other existing networks. Moreover, FSO provides highspeed connection up to Gbps, which is far more beyond the alternative systems.

#### FSO Advantages:

- Long distance up to 8 km.
- High bit rates speed rates: the high bandwidth capability of the fiber optic of 2.5 Gbps to 10 Gbps achieved with dense wavelength division multiplexing (DWDM). Modern systems can handle up to 160 signals and can thus expand a basic 10 Gbit/s system over a signal fiber pair to over 1.6 Tbit/s.
- Immunity from electromagnetic interference: secure cannot be detected with RF meter or spectrum analyzer, very narrow and directional beams
- Invisible and eye safe, no health hazards so even a butterfly can fly unscathed through a beam
- Low bit error rates (BER)
- Absence of side lobes
- Deployment of FSO systems quickly and easily
- Low maintenance (Practical)
- Lower costs as compared to fiber networks (FSO costs are as low as 1/5 of fiber network costs).
- License-free long-range operation (in contrast with radio communication)

#### FSO disadvantages:

For terrestrial applications, the principal limiting factors are beam dispersion, atmospheric absorption, rain, fog, snow, interference from background light sources (including the sun), shadowing, pointing stability in wind, and pollution.

#### Atmospheric effects:

Transmitted power of the emitted signal is highly affected by scattering, absorption and turbulence.

Attenuation is the result of absorption and scattering by molecules and particles (aerosols) suspended in the atmosphere.

Distortion, on the other hand, is caused by atmospheric turbulence due to random index of refraction fluctuations.

Attenuation affects the mean value of the received signal in an optical link whereas distortion results in variation of the signal around the mean.

### Aerosols:

Aerosols are particles suspended in the atmosphere with different concentrations. Each aerosol cause absorption and scattering.

They have diverse nature, shape, and size. Aerosols can vary in distribution, constituents, and concentration. As a result, the interaction between aerosols and light can have a large dynamic, in terms of wavelength range of interest and magnitude of the atmospheric scattering itself. Some aerosols are rain, smoke, fog, snow, desert dust particles, human-made industrial particulates, maritime droplets.

Aerosol scattering are explained by Mie scattering theory because the sizes of aerosols are comparable to or larger than the wavelength of the optical communications.

Transmitted optical beams in free space are attenuated most by the fog and haze droplets mainly due to dominance of Mie scattering and absorption effects in the wavelength band of interest in FSO (0.5  $\mu$  m – 2  $\mu$  m).

The Mie scattering coefficient is

$$\beta_{a(scatter)} = \alpha_a N_a \text{ in } 1/\text{km}$$

where  $\alpha_a$  is the Mie scattering cross-section in  $\text{km}^2$  and  $N_a$  is the number density of air particles in  $1/\text{km}^3$ .

An aerosol's concentration, composition and dimension distribution vary temporally and spatially varying, so it is difficult to predict attenuation by aerosols. Although their concentration is closely related to the optical visibility, there is no single particle dimension distribution for a given visibility. Due to the fact that the visibility is an easily obtainable parameter, either from airport or weather data, the scattering coefficient  $\beta_{a(scatter)}$  is expressed as

$$\beta_{a(scatter)} = \left( \frac{3.91}{V} \right) \left( \frac{0.55}{\lambda} \right)^i$$

where  $V$  is the visibility (Visual Range) in km,  $\lambda$  is the incident laser beam wavelength  $\mu\text{m}$ ,  $i$  is the size distribution of the scattering particles which typically varies from 0.7 to 1.6 corresponding to visibility conditions from poor to excellent.

Also the absorption coefficient of the aerosol  $\beta_{a(absorb)}$  is found and the atmospheric transmittance due to an aerosol is found to be

$$\tau_{aerosol} = \exp\left(-\beta_{T(aerosol)}L\right)$$

where the total attenuation due to an aerosol is  $\beta_{T(aerosols)} = \beta_{a(scatter)} + \beta_{a(absorption)}$  and  $L$  is the link distance, i.e., the distance between from the transmitter and the receiver.

Thus, the total attenuation due to aerosols is found by evaluating the scattering and absorption coefficients of each aerosol present in the FSO link and by adding them to find  $\beta_{T(aerosols)}$  and  $\tau_{aerosols} = \exp(-\beta_{T(aerosols)}L)$ .

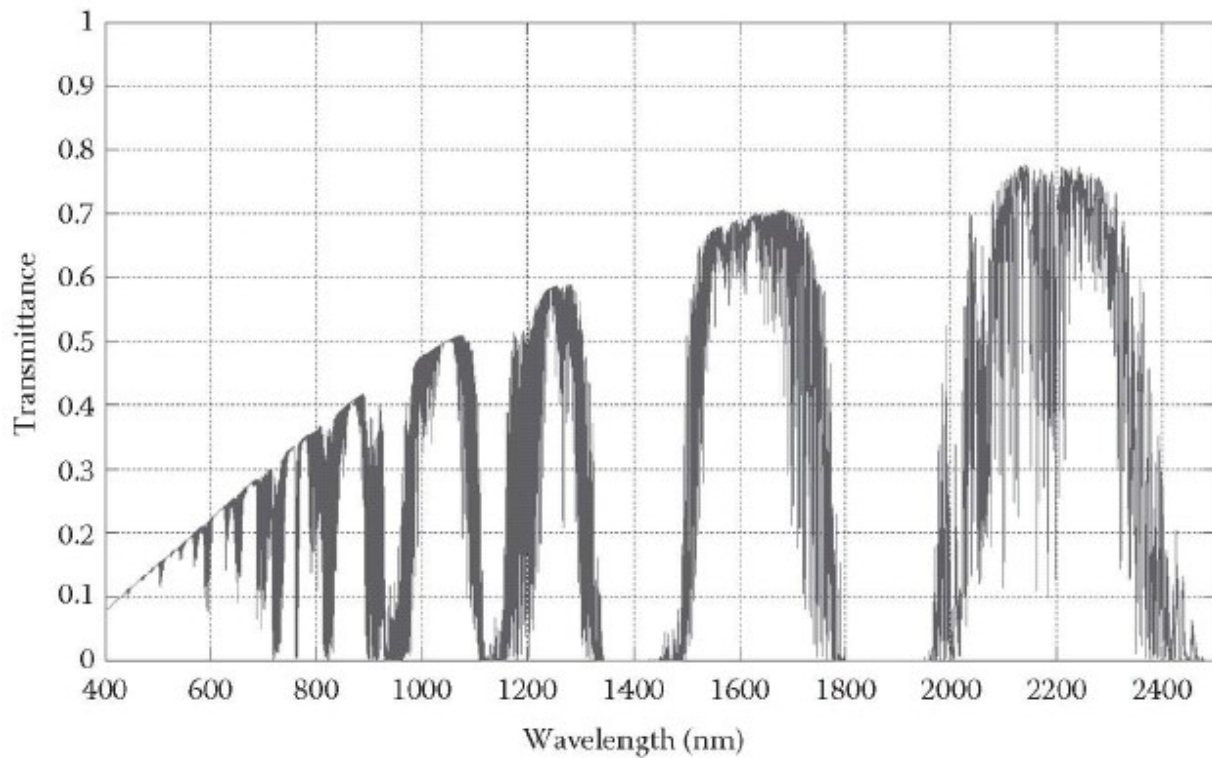

Atmospheric transmittance window with absorption contribution.

#### Molecules:

There are more than 40 different molecules in the atmosphere, e.g., nitrogen, hydrogen, carbon dioxide, ... etc. Each of these molecules cause scattering and absorption.

Rayleigh (molecular) scattering refers to scattering by molecular and atmospheric gases of sizes much less than the incident light wavelength. The Rayleigh scattering coefficient is given by

$$\beta_{m(scatter)} = \alpha_m N_m \text{ in } 1/\text{km}$$

where  $\alpha_m$  is the Rayleigh scattering cross-section in  $\text{km}^2$ ,

$N_m$  is the number density of air molecules in  $1/\text{km}^3$ .

Rayleigh scattering cross section is inversely proportional to fourth power of the wavelength of incident beam ( $\lambda^{-4}$ ) as

$$\alpha_{m(scatter)} = \frac{8\pi^3 (n^2 - 1)^2}{3N^2 \lambda^4} \text{ in km}^2$$

where  $n$  is the index of refraction,  $\lambda$  is the incident light wavelength in m,  $N$  is the volumetric density of the molecules in  $1/\text{km}^3$ .

The result is that Rayleigh scattering is negligible in the infrared waveband because Rayleigh scattering is primarily significant in the ultraviolet to visible wave range.

Also the absorption coefficient of the molecule  $\beta_{m(absorp)}$  is found and the atmospheric transmittance attenuation due to a molecule is found to be

$$\tau_{molecule} = \exp(-\beta_{T(molecule)}L)$$

where the total attenuation due to a molecule is  $\beta_{T(molecule)} = \beta_{m(scatter)} + \beta_{m(absorp)}$  and  $L$  is the link distance, i.e., the distance between from the transmitter and the receiver.

Thus, the total attenuation due to molecules is found by evaluating the scattering and absorption coefficients of each molecule present in the FSO link and by adding them to find  $\beta_{T(molecules)}$  and

$$\tau_{molecules} = \exp(-\beta_{T(molecules)}L).$$

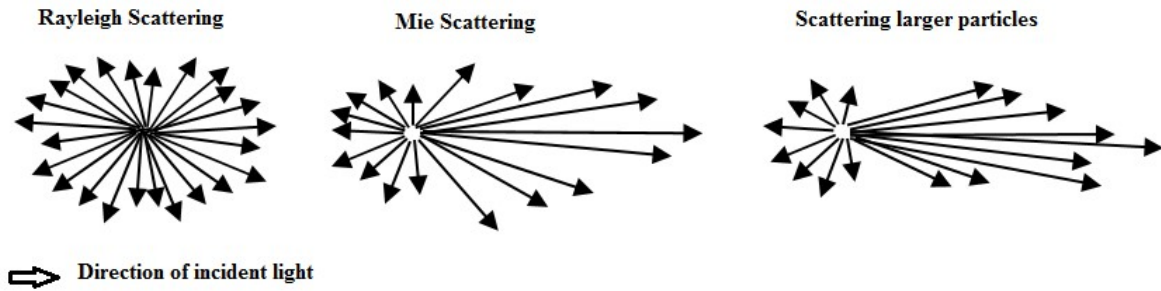

## Turbulence

Clear air turbulence phenomena affect the propagation of optical beam by both spatial and temporal random fluctuations of refractive index due to temperature, pressure, and wind variations along the optical propagation path.

Atmospheric turbulence primary causes phase shifts of the propagating optical signals resulting in distortions in the wave front.

These distortions, referred to as optical aberrations, also cause intensity distortions, referred to as scintillation.

Moisture, aerosols, temperature and pressure changes produce refractive index variations in the air by causing random variations in density.

These variations are referred to as eddies and have a lens effect on light passing through them.

When the light beam wave passes through these eddies, parts of it are refracted randomly causing a distorted wave front with the combined effects of variation of intensity across the wave front and warping of the isophase surface.

As the result, turbulence causes scattering  $\tau_{turbulence} = \exp(-\beta_{t(scatter)}L)$

i.e., the overall total attenuation due to aerosols, molecules and turbulence is found by  $\beta_{T(overall)} = \beta_{a(scatter)} + \beta_{a(absorp)} + \beta_{m(scatter)} + \beta_{m(absorp)} + \beta_{t(scatter)}$  and  $\tau_{overall} = \exp(-\beta_{T(overall)}L)$ .

Other effects of turbulence:

- Beam wander

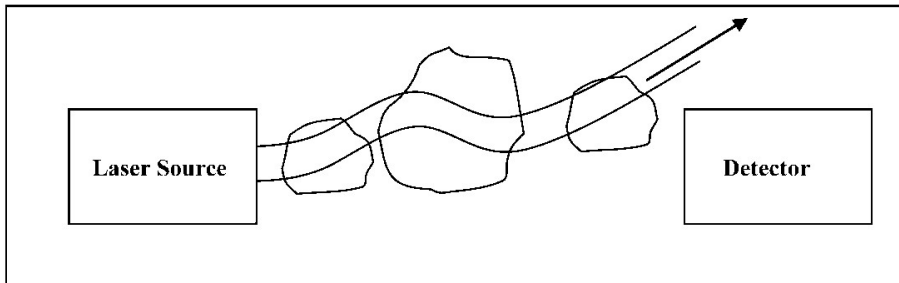

- Beam spread: Beam size at the receiver is increased further on top of free space diffraction.
- Intensity fluctuations: Intensity at the receiver fluctuates in time and space.

## 11. Propagation of Light in FSO

### Free-Space Propagation of Gaussian-Beam Waves

The mathematical description of a propagating wave involves a field.

Basically, a field  $u(\mathbf{R}, t)$  is a function of space  $\mathbf{R} = (x, y, z)$  and time  $t$  that satisfies a partial differential equation.

In the case of electromagnetic radiation, the field may be a transverse electromagnetic (TEM) wave, whereas for acoustic waves the field may represent a pressure wave.

The governing equation in most cases is the wave equation

$$\nabla^2 u = \frac{1}{c^2} \frac{\partial^2 u}{\partial t^2}$$

where  $c = 3 \times 10^8$  m/s is the speed of the propagating wave which is light and  $\nabla^2$  is the Laplacian operator defined in rectangular coordinates by

$$\nabla^2 u = \frac{\partial^2 u}{\partial x^2} + \frac{\partial^2 u}{\partial y^2} + \frac{\partial^2 u}{\partial z^2}.$$

If we assume that time variations in the field are sinusoidal (i.e., a monochromatic wave), then we look for solutions of the form  $u(\mathbf{R}, t) = U_0(\mathbf{R})e^{-i\omega t}$  where  $\omega$  is the angular frequency and  $U_0(\mathbf{R})$  is the complex amplitude of the wave which is the spatial field.

The substitution of this solution form into the wave equation leads to the time-independent reduced wave equation (or Helmholtz equation)

$$\nabla^2 U_0 + k^2 U_0 = 0 \quad \text{where } k \text{ is the optical wave number related to the optical wavelength } \lambda \text{ by } k = \omega / c = 2\pi / \lambda.$$

For optical wave propagation, Helmholtz equation can be further reduced to what is called the paraxial wave equation.

Let us assume the beam originates in the plane at  $z=0$  and propagates along the positive  $z$ -axis. If we also assume the free-space optical field at any point along the propagation path remains rotationally symmetric, then it can be expressed as a function of  $r = \sqrt{x^2 + y^2}$  and  $z$ .

Thus, the reduced wave equation in cylindrical coordinates can be written as

$$\frac{1}{r} \frac{\partial}{\partial r} \left( r \frac{\partial U_0}{\partial r} \right) + \frac{\partial^2 U_0}{\partial z^2} + k^2 U_0 = 0$$

Paraxial approximation can be made when the propagation distance of an optical wave along the  $z$ -axis is much greater than the transverse spreading of the wave.

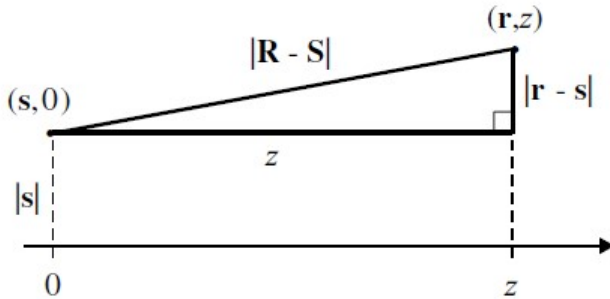

If  $\mathbf{R} = (\mathbf{r}, z)$  and  $\mathbf{S} = (\mathbf{s}, 0)$  denote two points in space with  $\mathbf{r}$  and  $\mathbf{s}$  transverse to the propagation axis, then the distance between such points is

$$|\mathbf{R} - \mathbf{S}| = \left( z^2 + |\mathbf{r} - \mathbf{s}|^2 \right)^{1/2} = z \left( 1 + \frac{|\mathbf{r} - \mathbf{s}|^2}{z^2} \right)^{1/2}$$

If the transverse distance is much smaller than the longitudinal propagation distance between the points, then the second factor can be expanded in a binomial series to obtain

$$|\mathbf{R} - \mathbf{S}| = z \left( 1 + \frac{|\mathbf{r} - \mathbf{s}|^2}{2z^2} + \dots \right) = z + \frac{|\mathbf{r} - \mathbf{s}|^2}{2z} + \dots, \quad |\mathbf{r} - \mathbf{s}| \ll z \quad \text{which is known as the paraxial approximation.}$$

The complex amplitude at propagation distance  $z$  from the source is given by Huygens-Fresnel integral as

$$U(\mathbf{r}, z) = -2ik \int_{-\infty}^{\infty} \int_{-\infty}^{\infty} G(\mathbf{s}, \mathbf{r}; z) U_0(\mathbf{s}, 0) d^2s$$

where  $U_0(\mathbf{s}, 0)$  is the optical wave at the source plane and  $G(\mathbf{s}, \mathbf{r}; z)$  is the free-space Green's function which can be expressed under the paraxial approximation as

$$G(\mathbf{s}, \mathbf{r}; z) = \frac{e^{ik|\mathbf{R}-\mathbf{S}|}}{4\pi|\mathbf{R}-\mathbf{S}|} \cong \frac{1}{4\pi z} \exp\left(ikz + \frac{ik}{2z}|\mathbf{r}-\mathbf{s}|^2\right)$$

The complex amplitude of the Gaussian-beam wave at the source plane  $z=0$  is

$$U_0(\mathbf{s}, 0) = A \exp\left(-\frac{1}{2}\alpha_0 k s^2\right) = A \exp\left[\frac{ik}{2z}(i\alpha_0 z) s^2\right] = A \exp\left[-\frac{s^2}{W_0^2} - \frac{ik}{2F_0} s^2\right]$$

where  $A$  is the amplitude at the origin,  $s = \sqrt{x^2 + y^2}$  is radial distance from the beam center line and  $\alpha_0 = \frac{2}{kW_0^2} + i\frac{1}{F_0}$ . It is assumed that the transmitting aperture is located in the plane  $z=0$  and the amplitude distribution in this plane is Gaussian with effective beam radius (spot size)  $W_0$  in meters, which denotes the radius at which the field amplitude falls to  $1/e$  of that on the beam axis as shown below for  $A=1$

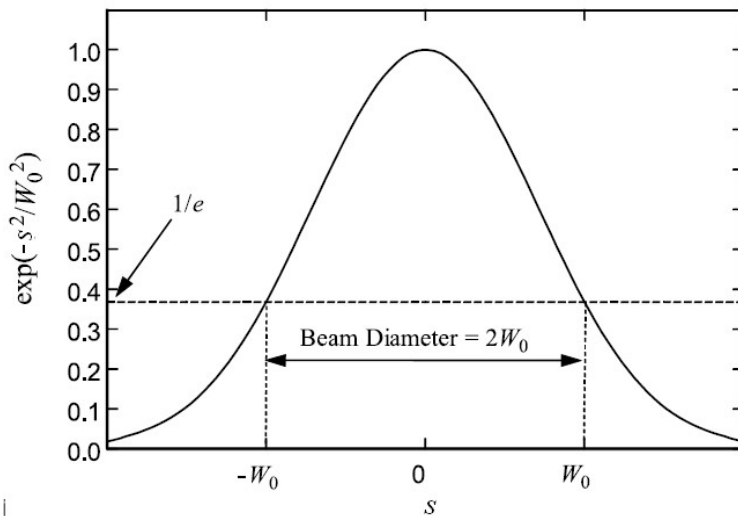

Additionally, the phase front is taken to be parabolic with radius of curvature  $F_0$  in meters. The particular cases  $F_0 = \infty, F_0 > 0, F_0 < 0$  correspond to collimated, convergent, and divergent beam forms, respectively

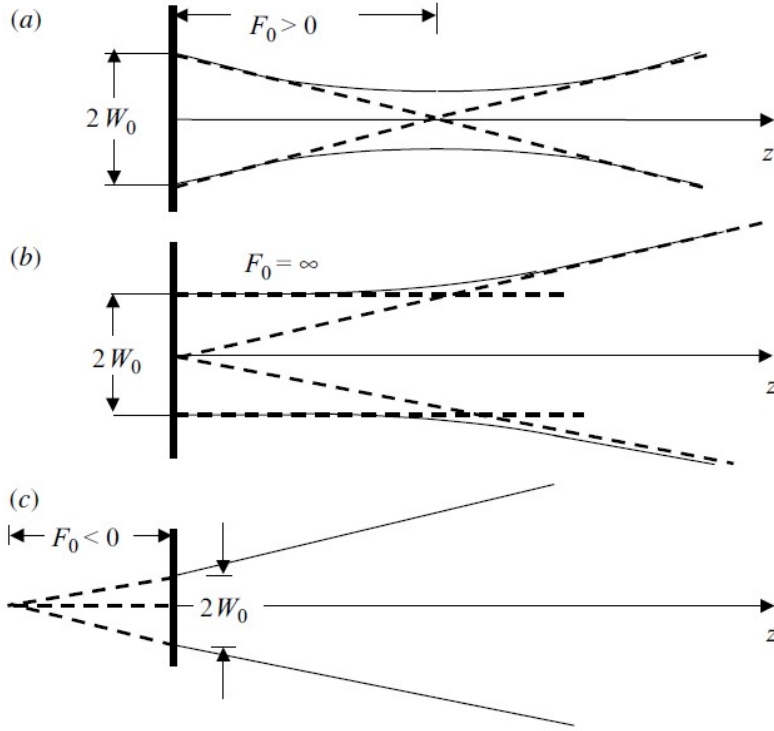

(a) Convergent beam, (b) collimated beam, and (c) divergent beam.

Thus, for the Gaussian beam, Huygens-Fresnel integral becomes

$$U(\mathbf{r}, z) = -2ik \int_{-\infty}^{\infty} \int_{-\infty}^{\infty} \frac{1}{4\pi z} \exp\left(ikz + \frac{ik}{2z} |\mathbf{r} - \mathbf{s}|^2\right) A \exp\left[\frac{ik}{2z} (i\alpha_0 z) s^2\right] d^2s$$

Changing the integration to polar coordinated where  $d^2s = sd\theta ds$  and rearranging

$$U(\mathbf{r}, z) = -\frac{Aik}{2\pi z} \exp\left(ikz + \frac{ik}{2z} r^2\right) \int_0^{\infty} \int_0^{2\pi} \exp\left(-\frac{ik}{z} rs \cos\theta\right) \exp\left[\frac{ik}{2z} (1 + i\alpha_0 z) s^2\right] sd\theta ds$$

Performing the integrations, the electric field at the receiver is found as

$$U(\mathbf{r}, z) = \frac{A}{1 + i\alpha_0 z} \exp\left[ikz + \frac{ik}{2z} \left(\frac{i\alpha_0 z}{1 + i\alpha_0 z}\right) r^2\right]$$

The intensity at the receiver is  $I(\mathbf{r}, z) = U(\mathbf{r}, z)U^*(\mathbf{r}, z)$

## 12. FSO Link Design

The ability for an optical link to deliver the signal power to the receiver is governed by the link equation

$$P_R = P_T \left( \eta_T \eta_A \frac{4\pi A_T}{\lambda^2} \right) L_{TP} L_{atm} L_{pol} L_{RP} \left( \frac{A_R}{4\pi z^2} \right) \eta_R$$

where

$P_R$  is the total signal power at the input to the receiver. For the uplink, this is defined at the input to the optical detector. For the downlink, the receive signal power is defined at the input to the receive optical detector,

$P_T$  is the transmit optical power at the transmit interface,

$\eta_T$  is the transmit optics efficiency,

$\eta_A$  is the aperture illumination efficiency of the transmitter lens,

$\lambda$  is the wavelength,

$A_T$  is the aperture area,

$L_{TP}$  is the transmitter pointing loss, defined as the ratio of power radiated in the direction of receiver to the peak radiated power. If the transmitter is directly pointed at the receiver, the pointing loss is 0 dB,

$L_{att}$  is the fractional loss due to absorption of the medium (e.g., earth atmosphere),

$L_{pol}$  is the fractional signal loss due to mismatch of the transmitting and receiving polarization patterns,

$L_{RP}$  is the receiver pointing loss, defined as the ratio of receiving lens gain in the direction of the transmitting lens to the peak receiving lens gain,

$A_R$  is the receive aperture area,

$z$  is the link distance,

the term  $\left(\frac{A_R}{4\pi z^2}\right)$  is the fraction of power that is collected by the receiving aperture if the transmitter is an isotropic radiator.

$\eta_R$  is the receiving optics collecting efficiency, defined as the fraction of optical power at the receiving aperture that is collected within the field of view of the receive detector.

Thus, the receive signal power can be improved by the following:

1) Increasing the transmit power. The most straightforward method of improving the receive signal power is to increase the power at the transmitter since the receive power scales linearly with the transmit power. However, increasing the transmit power also increases the overall system power consumption which, for a deep-space mission, is typically at a premium. Furthermore, the increased power consumption can lead to thermal management issues (increased radiator size and hence mass) for the host spacecraft, as well as reliability concerns.

2) Increasing the transmit aperture. This effectively reduces the transmit beamwidth and hence improves the power delivery efficiency. However, the pointing and tracking of the narrow downlink becomes increasingly more difficult with a narrower downlink. Furthermore, the aperture size is highly correlated with the mass of the transmit terminal and hence cannot be increased indefinitely.

3) Reducing the operating wavelength. Reducing the operating wavelength reduces the diffraction loss of the signal (i.e., reduces the transmit beamwidth). However, the wavelength selection is strongly constrained by the available laser technology, as well as considerations on the receiver sensitivity and detector technology. Furthermore, the transmittance of the atmosphere also depends on the wavelength, as well as the amount of sky background irradiance.

4) Increasing the receiver aperture area. Since the receive signal power scales linearly with the receive aperture area, increasing the receiver aperture area is a relatively simple way to improve the system performance. However, for daytime operations of a receiver inside the Earth's atmosphere, the amount of background noise collected also increases with increasing receiver aperture, and the effective performance improvement does not always scale linearly with increasing aperture area.

5) Reduced pointing loss. Reducing the pointing loss improves the overall signal energy and also reduces the point-induced signal power fluctuation.

6) Improving the overall efficiency, including transmit and receive optical loss, and polarization mismatch losses. This generally requires attention to the optical design. Of particular attention is the transmit optics design. The transmit aperture illumination efficiency,  $\eta_A$ , depends on the phase and intensity distribution over the aperture. For the general case of a transmit aperture being illuminated by a Gaussian beam, the aperture illumination efficiency can be written as:

$$\eta_A = \frac{2S}{\alpha^2} \left[ \exp(-\alpha^2 \gamma^2) - \exp(-\alpha^2) \right]^2$$

where  $\alpha$  is the ratio between the aperture diameter and the Gaussian beam ( $1/e^2$ ) diameter of the transmit signal,  $\gamma$  is the obscuration ratio (darkening ratio) and  $S$  is the Strehl ratio, which is defined as the intensity at the center of the aberrated system to that of an ideal optical system.

### Optical-Receiver Sensitivity

In addition to the effective delivery of the signal to the detector, the performance of the optical link also depends on the receiver sensitivity (measured in terms of received photons per bit). Because of the high cost associated with increasing the transmit power and system aperture, improving the receiver sensitivity is an important factor

In a direct-detection receiver, the received optical intensity is detected without extensive front-end optical processing.

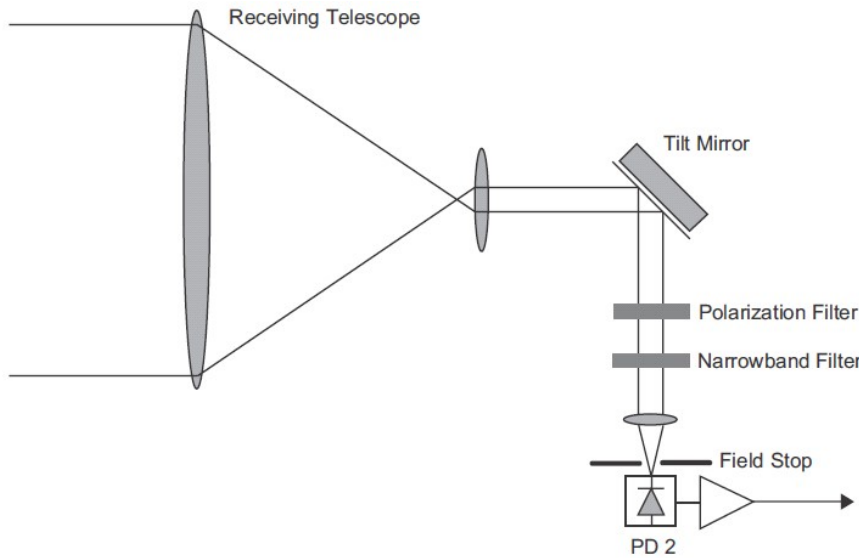

The incident signal is collected by the receive telescope. A polarization filter followed by a narrowband filter, and a field stop effectively reduces the amount of background noise incident onto the detector.

The capacity of a direct detection optical channel in the presence of background can be written as:

$$C = (\log_2 e) \frac{\lambda_s}{M} \left[ \left( 1 + \frac{1}{\rho} \right) \ln(1 + \rho) - \left( 1 + \frac{M}{\rho} \right) \ln \left( 1 + \frac{\rho}{M} \right) \right]$$

### Photon Detection Sensitivity

Improving the photon detection efficiency is an obvious method of improving the channel performance. For a direct-detection receiver, this is generally accomplished by using detectors with internal amplifications, such as avalanche photodiodes (APDs) and photomultiplier tubes (PMTs).

### Modulation Format

One practical modulation format to achieve high peak-to-average-power ratio is the M-ary pulse-position modulation (PPM). In an M-ary PPM modulation scheme, each channel symbol period is divided into M time slots, and the information is conveyed through the channel by the time window in which the signal pulse is present.

### Link Availability

The communications link budget or the DCT is a useful tool in estimating the physical layer link performance (e.g., the link bit error rate). An operational communications link, on the other hand, must also address the issue of link availability. Overall link availability is aimed at >90 percent depending on the link type. In some links, 99.999 % availability may be required.

### Beam Pointing and Tracking

Due to the narrow transmit beamwidth, accurate pointing acquisition and tracking are critical to the deep-space laser communications system implementation.

### Typical design parameters considered in an FSO link design:

Link Budget	Parameters
Received signal power	Operating wavelength
	Link distance
	Transmit power
	Transmit aperture area
	Transmit optics efficiency
	Transmit Strehl ratio
	Transmit pointing loss
	Polarization mismatch loss
	Receiver aperture area
	Receive optics efficiency
	Receiver detector field of view
	Receiver pointing loss
	Atmospheric attenuation loss
	Scintillation-induced loss
Received background power	Receive aperture area

Receive optics efficiency
Detector field of view
Receive optical bandwidth
Background spectral irradiance
Receive optics scattering behavior
Detector dark count

Receiver sensitivity	Detector quantum efficiency
	Detector noise characteristics • Dark count rate or • Detector Excess and thermal noise
	Modulation format
	Coding scheme

### Direct Detection System

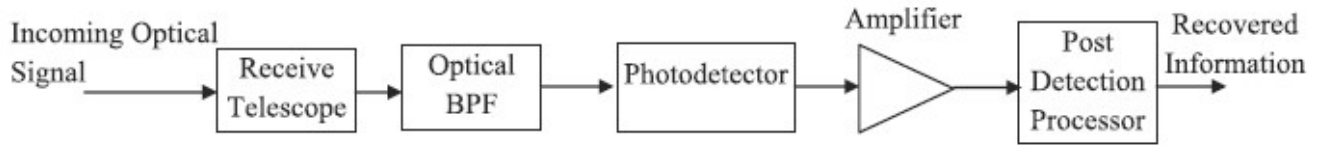

Block diagram of a direct detection scheme

In direct detection technique, the received optical signal is passed through optical band-pass filter to restrict the background radiation.

It is then allowed to fall on the photodetector which produces the output electrical signal proportional to the instantaneous intensity of the received optical signal.

It may be regarded as linear intensity to current convertor or quadratic (square law) convertor of optical electric field to detector current.

The photodetector is followed by an electrical low-pass filter (LPF) with bandwidth sufficient enough to pass the information signal.

The signal-to-noise ratio (SNR) of direct detection receiver can be obtained by using noise models for a particular detector, i.e., PIN or avalanche photodetector (APD).

With the received power as given above by

$$P_R = P_T \left( \eta_T \eta_A \frac{4\pi A_T}{\lambda^2} \right) L_{TP} L_{atm} L_{pol} L_{RP} \left( \frac{A_R}{4\pi z^2} \right) \eta_R$$

and detector noise sources, the SNR expressions are obtained for PIN photodetector to be

$$SNR = \frac{(R_0 P_R)^2}{2qB(R_0 P_R + R_0 P_B + I_d) + 4K_B TB / R_L}$$

where  $B$  is the receiver bandwidth,  $I_d$  is the dark current,  $K_B=1.3807 \times 10^{-23}$  joules per kelvin ( $J \cdot K^{-1}$ ) is the Boltzmann's constant,  $T$  is the absolute temperature,  $R_L$  is the equivalent load resistance,  $P_B$  is the background noise power and  $R_0$  in mA/watt is the detector responsivity given by

$$R_0 = \frac{\eta q}{h\nu}$$

where  $\eta$  is the detector quantum efficiency,  $q=1.602 \times 10^{-19}$  Coulomb is the electronic charge,  $h=6.623 \times 10^{-34}$  Joule.sec is the Planck's constant,  $\nu$  the operating frequency.

When APD is used, the dark current and shot noise are increased by the multiplication process; however, the thermal noise remains unaffected. Therefore, if the photocurrent is increased by a factor of  $M$  avalanche multiplication factor, then the total shot noise is also increased by the same factor. For the surface dark current  $I_{ds}=0$ , the direct detection SNR for APD photodetector is

$$SNR = \frac{(MR_0P_R)^2}{2qB(R_0P_R + R_0P_B + I_{db})M^2F + 4K_BTB/R_L}$$

where  $F$  is the excess noise factor arising due to random nature of multiplication factor,  $I_{db}$  is the bulk dark current.

Since the photodetector response is insensitive to the frequency, phase, or polarization of the carrier, this type of receiver is useful only for intensity-modulated signals.

### 13. Optical Wireless Communication in Underwater Medium

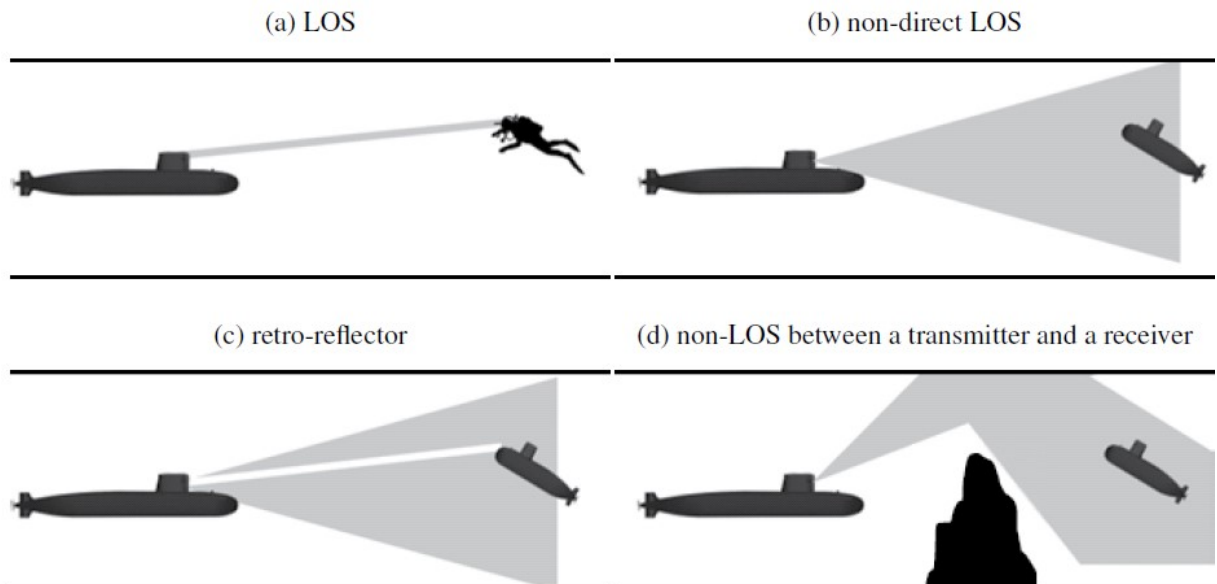

Different underwater optical wireless link configuration.

Optical wireless communications are a relatively new technology providing many serious advantages, such as the very high rates of data transmission, secure links, very small and light.

Optical waves in the visible spectrum (400–700 nm) present an alternative way to provide broadband communications in the water. They propagate faster in water (300,000,000 m/s) than the acoustic ones (340 m/s in air, 1500 m/s in water), which is about 200,000 times faster than sound travels through water. That is the main reason why they have gained a considerable interest during the last years to serve as a broadband (10–100 Mbps), safe (non-interceptable) and reliable complement to acoustic underwater communications systems.

In general, optical signals are highly absorbed in water, and this is one of the main disadvantages; the other one is the optical scattering by all the particles existing inside the sea. However, seawater shows a decreased absorption in the blue/green region of the visible spectrum. Thus, using suitable wavelengths, for instance in the blue/green region, high speed connections can be attained according to the type of water (400–500 nm for clear to 300–700 nm for turbid water conditions). Minimum attenuation is centered near 0.460  $\mu\text{m}$  in clear waters and shifts to higher values for dirty waters approaching 0.540  $\mu\text{m}$  for coastal waters.

The power received  $P(z)$ , given initial power  $P_0$ , propagating through a medium of thickness  $z$  is estimated by the Beer's Law given by

$$P(z) = P_0 e^{-c(\lambda)z}$$

where  $c(\lambda)$  in  $\text{m}^{-1}$  is the extinction coefficient expressing the total attenuation occurred by the propagation through the water.

The total attenuation can be described as the sum of absorption and scattering. Thus,

$$c(\lambda) = \alpha(\lambda) + \beta(\lambda)$$

where  $\alpha(\lambda)$  is the absorption coefficient,  $\beta(\lambda)$  is the scattering coefficient and the product  $cz$  is the attenuation length, and it contributes on the reduction of the received power by a factor of  $\exp(-1)$ , or  $\sim 63\%$ .

Beer's Law provides a limited applicability as it describes only the attenuation due to absorption and single scattering events. In reality, however, many cases of multiple scattering may occur. Also it presumes that the source and receiver are in exact alignment with each other, and it can be applied only in Line-of-Sight (LOS) communication scenarios. Moreover, Beer's Law ignores temporal dispersion.

More accurate expressions have to take the link geometry into account. For instance, assuming that the transmitter and receiver are positioned in a non LOS configuration, the received power dependent on time  $t$ , lateral displacement from the beam axis  $r$ , and range  $z$  is

$$P_R(t, r, z) = P_T(t) D_T L_w(t, r, z) D_R$$

where  $P_T(t)$  is the transmitted power,  $D_T$  is the aperture and divergence of the optical source, and  $D_R$  is the photoreceiver aperture and field of view. The channel loss term,  $L_w(t, r, z)$ , characterizes the spatial and temporal characteristics of light propagation in seawater.

## UOWC propagation

### Underwater medium characteristics

Underwater medium contains almost 80 different elements, dissolved or suspended in pure water, with different concentrations. Some of them are

- Various dissolved salts such as NaCl, MgCl<sub>2</sub>, etc, which absorb light at specific wavelengths and induce scattering effects.
- Minerals like sand, metal oxides, which contribute to both absorption and scattering.
- Colored dissolved organic matters such as fulvic and humic acids which affect absorption, mainly in blue and ultraviolet wavelengths.
- Organic matters such as viruses, bacteria, and organic detritus which add backscattering, especially in the blue spectral range.
- Phytoplankton with chlorophyll-A which strongly absorbs in the blue-red region and scatters green light.

Since chlorophyll absorbs the blue and red wavelengths and the particles strongly contribute to the scattering coefficient, we can use its concentration  $C$  (in mg/m<sup>3</sup>) as the free parameter to calculate the absorption and scattering coefficients.

The exact type of water plays a significant role in the estimation of the amount of chlorophyll concentration and consequently the amount of absorption and scattering for a specific geographic location. A classification system for the clarity of water types based on their spectral optical attenuation depth was proposed by Jerlov.

The four major water types are

- Pure deep ocean waters cobalt blue where the absorption is high and the scattering coefficient is low.
- Clear sea waters with higher scattering due to many dissolved particles.
- Near coasts ocean waters with absorption and scattering due to planktonic matters, detritus and mineral components.
- Harbor murky waters, which are quite constraining for optical propagation due to dissolved and in-suspension matters.

### Absorption

The absorption coefficient,  $\alpha(\lambda)$  is the ratio of the absorbed energy from an incident power per unit distance due to various dissolved particles such as phytoplankton, detritus, etc.

$$\alpha(\lambda) = \alpha_w(\lambda) + \alpha_c^0(\lambda) \left( C_c / C_c^0 \right)^{0.602} + \alpha_f^0 C_f e^{-k_f \lambda} + \alpha_h^0 C_h e^{-k_h \lambda}$$

where  $\alpha_w(\lambda)$  is the absorption by the pure water in m<sup>-1</sup>,  $\lambda$  is the wavelength in nm,  $\alpha_c^0(\lambda)$  is the absorption coefficient of chlorophyll in m<sup>-1</sup>,  $C_c$  is the total concentration of chlorophyll per cubic meter ( $C_c^0 = 1\text{mg/m}^3$ ),  $\alpha_f^0 = 35.959 \text{ m}^2/\text{mg}$  is the absorption coefficient of fulvic acid,  $k_f = 0.0189 \text{ nm}^{-1}$ ,  $C_f =$

$0.0189 \text{ nm}^{-1}$ ,  $\alpha_h^0 = 18.828 \text{ m}^2/\text{mg}$  is the absorption coefficient of humic acid and  $k_h = 0.01105 \text{ nm}^{-1}$ . The concentrations  $C_f$  and  $C_h$  are expressed as

$$C_f = 1.74098 C_c e^{0.12327(C_c/C_c^0)}$$

$$C_h = 0.19334 C_c e^{0.12343(C_c/C_c^0)}$$

### Scattering

Scattering coefficient,  $\beta(\lambda)$  is the ratio of energy scattered from an incident power per unit distance. It is the sum of backward scattering,  $\beta_b(\lambda)$  and forward scattering coefficient,  $\beta_f(\lambda)$ .

Scattering is caused by small and large particles. Small particles are the particles with refractive index equal to 1.15, whereas large particles have a refractive index of 1.03. The scattering and backscattering coefficients are

$$\beta(\lambda) = \beta_w(\lambda) + \beta_s^0(\lambda)C_s + \beta_l^0(\lambda)C_l$$

$$\beta_B(\lambda) = 0.5\beta_w(\lambda) + 0.039\beta_s^0(\lambda)C_s + 6.4 \times 10^{-4} \beta_l^0(\lambda)C_l$$

For small and large particulate matter

$$\beta_s^0(\lambda) = 1.151302 \left( \frac{400}{\lambda} \right)^{1.7}$$

$$\beta_l^0(\lambda) = 0.341074 \left( \frac{400}{\lambda} \right)^{0.3}$$

and the concentrations are

$$C_s = 0.01739 C_c e^{0.11631(C_c/C_c^0)}$$

$$C_l = 0.76284 C_c e^{0.03092(C_c/C_c^0)}$$

### Oceanic turbulence

Optical wireless communications are greatly affected by optical turbulence, which refers to random fluctuations of the refraction index.

In the case of underwater systems, these fluctuations are mainly caused by variations in temperature and salinity of the oceanic water.

An important parameter for the description of oceanic turbulence is the scintillation index, which expresses the variance of the wave intensity.

### Link budget

Empirical path loss models are effective enough to estimate the received optical power for underwater communications under LOS conditions.

$$P_R = P_T \eta_t \eta_r e^{-\frac{c(\lambda)R}{\cos\theta}} \frac{A_R \cos\theta}{2\pi R^2 (1 - \cos\theta)}$$

where  $P_T$  is the transmitted power,  $\eta_t$  and  $\eta_r$  are the optical efficiencies of the Tx and Rx correspondingly,  $c(\lambda)$  is the extinction coefficient,  $R$  is the perpendicular distance between the Tx plane and the Rx plane,  $\theta_0$  is the Tx beam divergence angle,  $\theta$  is the angle between the perpendicular to the Rx plane and the Tx-Rx trajectory, and  $A_R$  is the receiver aperture area.

## **14. All Optical Networking**

All optical networks aim at very high data rates in the overall telecommunication network by replacing all the network elements by optical elements.

- High-capacity telecommunications networks.
- Based on all optical components.
- All the network is to be designed with all optical elements, thus bandwidth will not be a limiting factor since opto electronic conversions will not be needed throughout the network.

### General considerations in all optical networks:

Electro/Optics and Opto/electronic conversions limit the use of optical network advantage in very high data bit rates because electronics can not handle very high data rates as the optics can handle.

Without optical Add-Drop Multiplexers, each location that demultiplexes signals will need an electrical network element for each channel, even if no traffic is dropping at that site.

By implementing an optical network, only those wavelengths that add or drop traffic at a site need corresponding electrical nodes. Other channels can simply pass through optically, which provides tremendous cost savings in equipment and network management.

In addition, performing space and wavelength routing of traffic avoids the high cost of electronic cross-connects.

**Wavelength Services:** In optical networks, service providers are able to resell bandwidth rather than fiber. By maximizing capacity available on a fiber, service providers can improve revenue by selling wavelengths, regardless of the data rate required. To customers, this service provides the same bandwidth as a dedicated fiber.

### Currently employed optical elements in the telecommunications network:

- Optical fibers:

First, more capacity between two sites meant the installation of more fibers.

Then more time division multiplexed (TDM) signals are placed in the same fiber, i.e. the bandwidth handling capability of the fibers were increased. (both through fiber manufacturing and semiconductor laser modulation techniques supporting high rates of 40 Gbps.)

- Optical networks with Dense Wavelength Division Multiplexing (DWDM) provide additional capacity on existing fibers. DWDM is introduced providing many virtual fibers on a single physical fiber which increased drastically the information rate carrying capability of fibers (in the order of hundreds of Terabits per second).

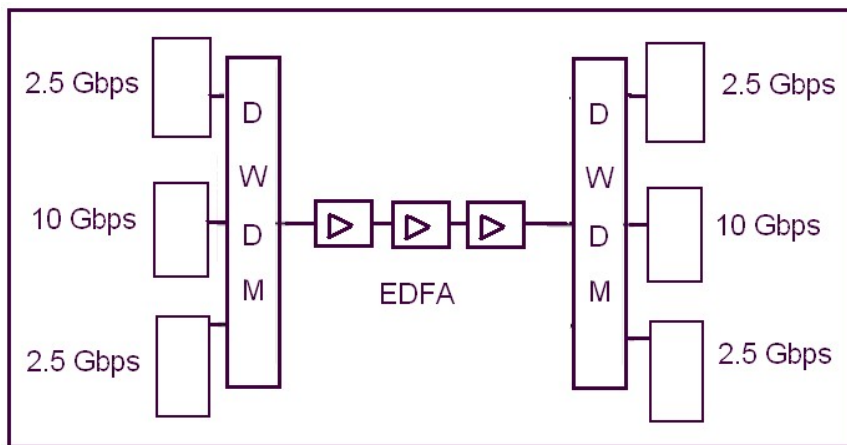

- ITU Channel Spacing is shown below:

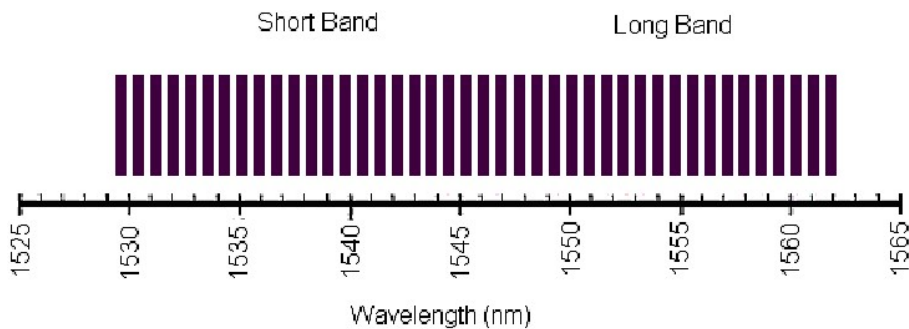

- Two basic types of DWDM:

- Unidirectional: All the wavelengths travel in the same direction on the fiber

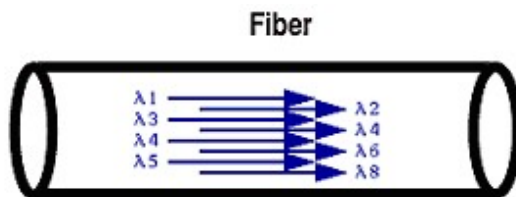

- Bidirectional: Signals are split into separate bands, with both bands traveling in different directions.

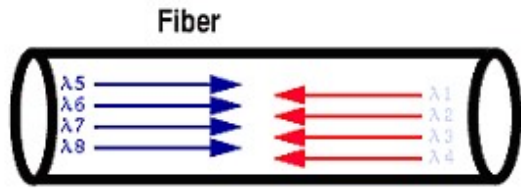

- SDH/SONET.
- Optical Amplifiers
  - Erbium-Doped Fiber Amplifier (EDFA). By doping a small strand of fiber with a rare earth metal, such as erbium, optical signals could be amplified without converting the signal back to an electrical state.
  - EDFA operating at 1550 nm is used at each 50 – 100 km and replaces electronic regenerators.
  - EDFA enables data rates of 10 Gbps or higher. With the electronic conversion the rate was limited by 2.5 Gbps.
- Laser diodes used in optical fiber communications.
- LED light sources.
- Optical detectors used in optical fiber communications.
- Tunable Lasers:
  - Radiate light at different wavelengths.
  - Can switch from one wavelength to another very quickly.
- Narrowband Lasers
  - Advanced lasers have extremely narrow source spectral bandwidths ( $\ll 1$  nm), very narrow wavelength spacings.
  - Long-haul applications use externally modulated lasers, while shorter applications can use integrated laser technologies.

Optical elements that are not yet currently employed in the telecommunications network:

- Optical Switches (Sometimes referred to as Optical Cross Connects or Wavelength Routers)
  - Switch takes traffic in electrical form from an input port or connection and directs it again in electrical form over a backplane, to an output port.
  - Electronic switches direct variable-length packets, fixed-length cells, and synchronous timeslots from an input port to an output port.

An electronic space switching is shown below:

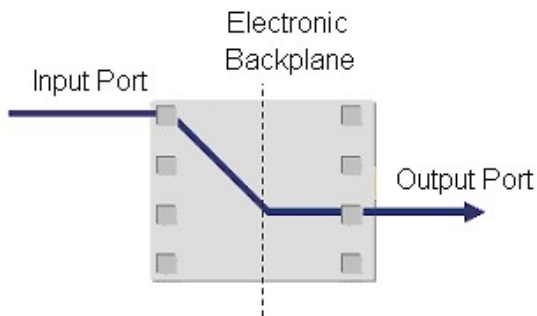

An optical switch works with light. It directs a light beam of a single wavelength or of a range of wavelengths from an input port to an output port.

An optical space switching is shown below:

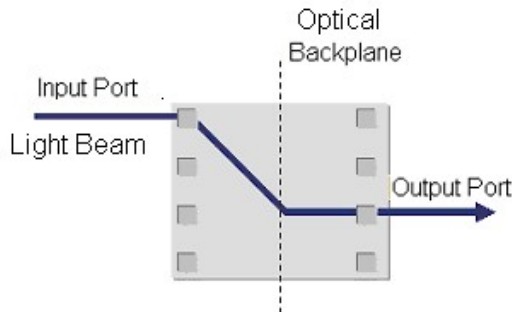

A switch needs some kind of information to make the switching decision. In electronic switches, this information is carried inside packets.

An IP switch, or router, uses the destination IP address ( $IP_D$ ) to make its decision.

The criterion of the optical switch for making a forwarding decision is carried in the so called digital wrapper around each input wavelength of the light.

Wrapper is equivalent to packet header which carries information such as what type of traffic is in the wavelength, where the traffic is headed, ... etc.

As the wavelength moves around the network, the nodes read the wrapper and get the information for originating and terminating details, whether it carries an IP or ATM or another protocol signal, commands such as error correction and whether the wavelength needs to be rerouted.

### Types of Optical Switches:

- MEMS (Micro Electro Mechanical System) Switches:

Light in one fiber is just redirected to move to a different fiber by using microscopic (with diameters of a human hair) moveable (moveable in three dimensions) mirrors (several hundred mirrors placed together on mirror arrays in an area of a few centimeters square).

Light from an input fiber is aimed at a mirror, which is directed to move the light to another mirror on a facing array.

Light beams themselves tell the mirror (through digital wrappers) what bend to make in order to route the light appropriately.

This mirror then reflects the light down towards the desired output optical fiber.

There exists designs of 1,024 x 1,024 wavelengths (if each can carry 40 Gbps it corresponds to a capacity of 40 Gbps x 1,024 = 40.96 Tbps) in an area of around 25 cm x 15 cm.

Picture of a MEMS mirror and MEMS mirror array deflection mechanism are shown below:

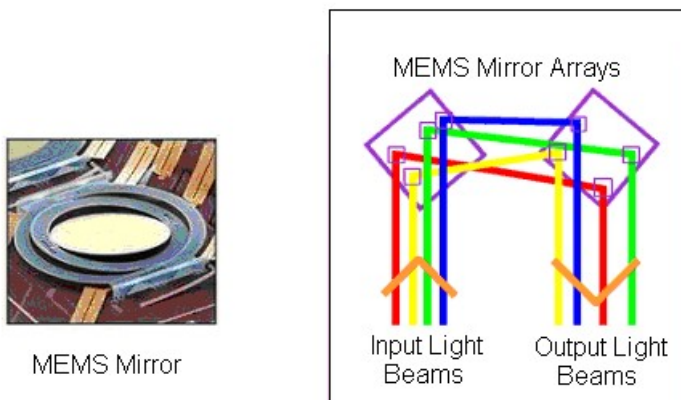

- Buble Switches: Use heat to create small bubbles in fluid channels which then reflect and direct light
- Thermo-optical Switches:

Light passing through glass is heated up or cooled down by using electrical coils.

Heat alters the refractive index of the glass, bending the light to enter one fiber or another.

- Liquid Crystal (LCD) Switches:

Use liquid to bend light

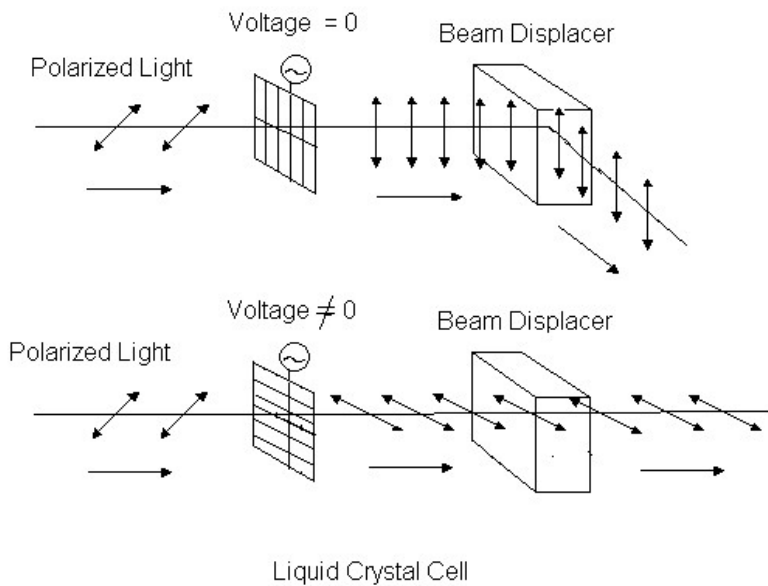

Wavelength Switching:

Single wavelength enters the switch

A “wavelength” selection is made by using prisms, filters or gratings.

Based on the wavelength selected, the light is switched to a known output port.

- Optical Burst Switching:

Disadvantage of lambda switching is that, once a wavelength has been assigned, it is used exclusively by its “owner.”

If 100 percent of its capacity is not in use for 100 percent of the time, then there is an inefficiency in the network.

A solution to this is to allocate the wavelength for the duration of the data burst being sent giving rise to optical burst switching.

- Optical Packet Switching (OPS):

OPS is the optical equivalent of an electronic packet switch, reading the embedded label and making a switching decision using this information.

- Holographic Switching:

- Creates a wavelength-specific reflective grating, but does this dynamically.
- The grating structure in these devices is written as a hologram into a piece of glass.
- The holograms are “invisible” until they are energized by a set of control electrodes.

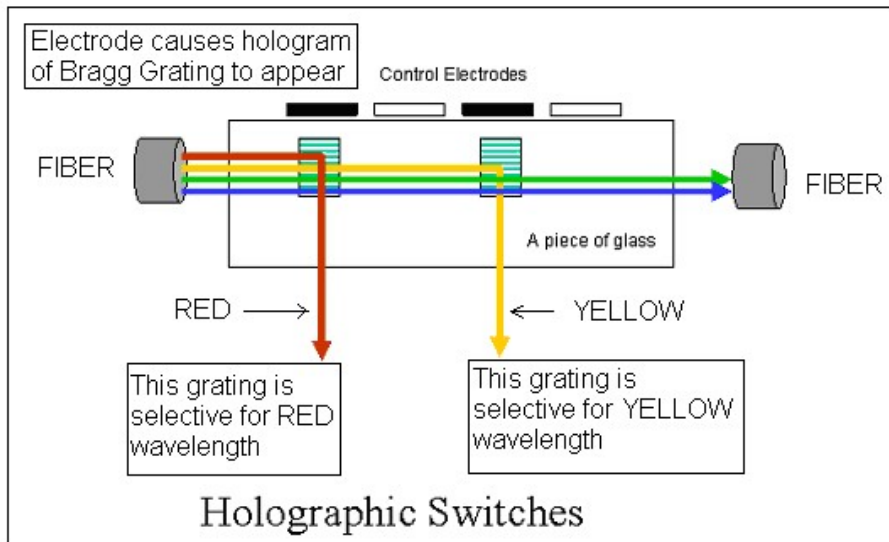

- Optical Add/Drop Multiplexers

#### Fiber Bragg Gratings

- It is a small section of fiber modified to create periodic changes in the index of refraction.
- Depending on the space between the changes, a certain frequency of light - the Bragg resonance wavelength - is reflected back, while all other wavelengths pass through.

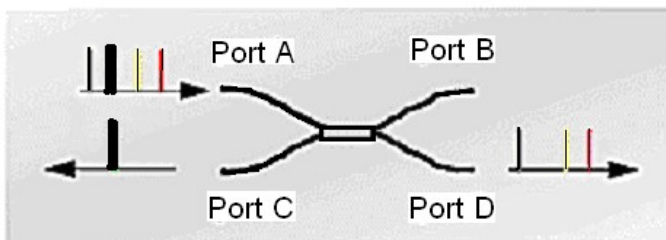

- Optical filters: Fiber Bragg gratings are also used in signal filtering.
- Multiplexers, demultiplexers

#### Thin Film Substrates

- By coating a thin glass or polymer substrate with a thin interference film of dielectric material, the substrate can be made to pass through only a specific wavelength and reflect all others.
- By integrating several of these components, optical network devices such as multiplexers, demultiplexers and add/drop devices are designed.